

IOM RAF 6R8R

Pressure Sustaining & Reducing Valve 2" - 4"

RAPHAEL VALVES INDUSTRIES

DESCRIPTION

This pressure reducing / sustaining valve is an automatic control valve designed to perform two functions; 1. To sustain an upstream pressure to a preset minimum. 2. To reduce a higher upstream pressure into a preset lower downstream pressure, and to maintain this pressure constantly regardless of flowrate or upstream pressure fluctuations.

INSTALLATION

- Before installing the RAF, flush the pipeline to remove scale, dirt and other particles that might affect the valve's performance.
- Install the RAF as indicated by the arrow on the valve's cover, showing flow direction.
- It is recommended to install isolation valves upstream and downstream the control valve.
- Turn the 3-way selector #5 to the "Close" position and turn on the water supply to the RAF.
- Check for leaks; tighten bolts & fittings if necessary.

PARTS LIST

1. Body
2. Cover
3. Diaphragm
4. Self-Flushing "Finger" Filter
5. 3-Way Selector
6. 3-Way Sustaining Pilot Model PSR
7. Pressure Adjusting" Screw
8. 3-Way Reducing Pilot Model PR
9. Pressure Adjusting Screw

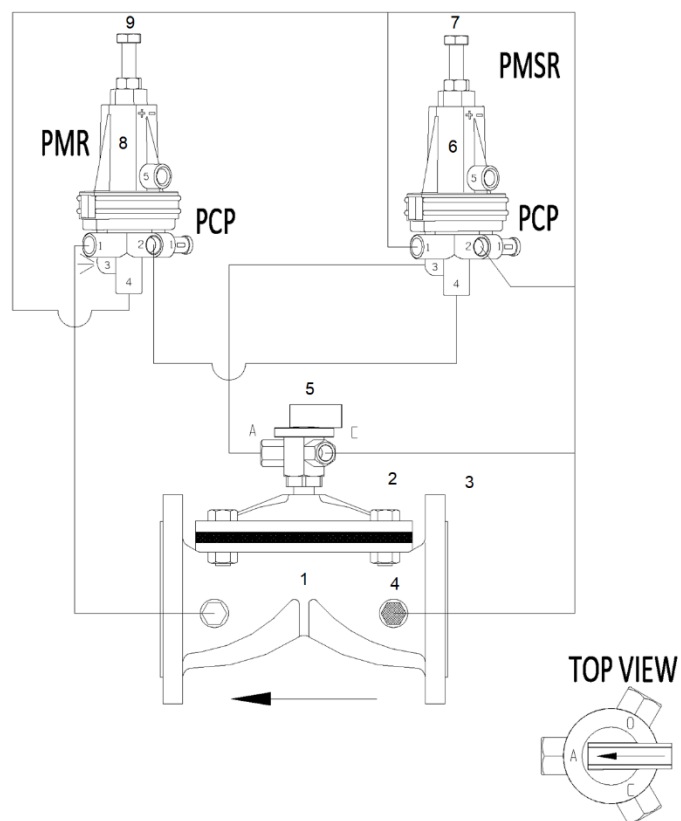

OPERATING INSTRUCTIONS

1. Make sure that there is a downstream flow demand.
2. Turn adjusting screw #7 clockwise all the way.
3. Turn adjusting screw #9 clockwise all the way.
4. Turn the 3-way selector #5 to the "Auto" position.
5. Turn adjusting screw #7 counterclockwise, until water will be discharged from the discharge port of pilot #6.
6. the RAF will start to open.
7. To decrease upstream pressure that will make the RAF open, continue to turn adjusting screw #7 counterclockwise one turn at a time, allowing some time between turns for the valve to respond. Check upstream pressure until required pressure is achieved.
8. To increase minimum upstream pressure, turn adjusting screw #7 clockwise one turn at a time, allowing some time between turns for the valve to respond. Check upstream pressure until required pressure is achieved.
9. To decrease downstream pressure, turn adjusting screw #9 counterclockwise one turn at a time, allowing some time between turns for the RAF to respond. Check downstream pressure until required pressure is achieved.
10. To increase downstream pressure, turn adjusting screw #9 clockwise one turn at a time, allowing some time between turns, allowing the valve to respond. Check downstream pressure until required pressure is achieved.

To open the RAF completely, turn the 3-way selector #5 to the "Open" position. Please note that by so doing the pressure downstream will be as high as the pressure upstream.

To close the RAF, turn the 3-way selector #5 to the "Close" position.

To maintain preset pressures, turn the 3-way selector to the "Auto" position.

MAINTENANCE

- No maintenance is required. However, from time to time it is recommended to rotate the 3-way selector 360° to prevent sticking by sediments.
- Check pressures. Adjust if required.
- It is recommended that the valve will be easily accessible as well as clearly marked to prevent damage.
- In freezing climates, the valve should be dismantled, and water drained during the winter months.

TROUBLESHOOTING RAF 6R31

PROBLEM	CAUSE	CHECK	SOLUTION
The RAF does not open.	<ol style="list-style-type: none"> The 3-Way selector (5) in the "Close" position. The 3-Way selector (5) is clogged or damaged. Upstream pressure is lower than the preset sustained pressure. One or both pilots are clogged or damaged. 	<ol style="list-style-type: none"> Check state of selector. Turn selector to 'Open' position; No water is vented. Check upstream pressure. No water vented from pilot's vent port. 	<ol style="list-style-type: none"> Turn selector to "Auto" position. Turn off water supply to the RAF. Dismantle the 3-Way selector, clean ports inlet or replace if required. Reassemble and activate. Increase upstream pressure or reduce set pressure upstream. Turn off water supply to the Raf. Clean water -passageways. If needed - Replace damaged pilot(s).
The RAF does not close.	<ol style="list-style-type: none"> The 3-Way selector is in the "Open" position. Foreign object on sealing seat or - damaged diaphragm. <p>Blocked self flushing filter (4).</p>	<ol style="list-style-type: none"> Check state of selector. Some water is still flowing downstream or constant flow of water through the 3-Way selector when it is turned to the 'Open' position. <p>Very little flow from port # 4 when the tube is disconnected.</p>	<ol style="list-style-type: none"> Turn selector to the "Auto" or "Close" position. Turn off water supply to the RAF. Dismantle the cove and diaphragm then remove the foreign object. Check that diaphragm body and cover are not damaged. Replace if needed. Reassemble and activate. Turn off water supply to the RAF. Remove filter (4). Clean or replace if needed. Reassemble and activate.
Unstable pressure	<ol style="list-style-type: none"> Blocked or damaged pilots #6 / #8. 	<ol style="list-style-type: none"> Unstable pressure downstream of the RAF. Or, upstream pressure not met. 	<ol style="list-style-type: none"> Turn off water supply to the RAF. Dismantle and clean drains in pilots. Check membranes. In case of internal parts wear, change pilot(s). Reassemble and activate.

RAPHAEL, founded in 1949, is the first Israeli manufacturer of water control valves. RAPHAEL 's research department constantly strives to introduce new and innovative products and solutions for water control systems including water works, fire-protection and irrigation systems.



Waterworks



Fire Protection



Irrigation



Smart Solutions

 **RAPHAEL**

RAPHAEL Valves Industries (1975) Ltd.

North Industrial Zone Or Akiva, 3063927 P.O.Box 555, Israel

Tel. +972 4 6263555 | info@raphael-valves.com | raphael-valves.com