



IOM ULTRAF 630T

Ultrasonic Hydrometer 3W Pressure Reducing
& Shuttle T relay, Metal Pilot, w/ Pulse
1.5" - 8"



 **RAPHAEL**

Apr-24

DESCRIPTION

This water meter and pressure reducing valve is an automatic NC (**Normally Closed**) hydraulically remote-controlled valve designed to reduce a higher upstream pressure into a preset lower downstream pressure and to maintain this pressure constantly regardless of flow-rate or upstream pressure fluctuations. “Normally” means the state of the valve when the shuttle T is pressurized.

INSTALLATION

- Before installing the Ultraf, flush the pipeline to remove scale, dirt and other particles that might affect the valve’s performance.
- Install the Ultraf as indicated by the arrow on the body, showing flow direction.
- Make sure that the shuttle T 8 is connected to the control’s pressure source.
- It is recommended to install isolation valves upstream and downstream the control valve.
- Turn the 3-way selector 5 to the “close” position and turn on the water supply to the Ultraf.
- Check for leaks; tighten bolts & fittings if necessary.

PARTS LIST

1. Body
2. Cover
3. Diaphragm
4. Self-flushing “finger” filter
5. 3 way selector
6. 3-way pilot model P683
7. Pressure adjusting screw
1. Shuttle (selector)

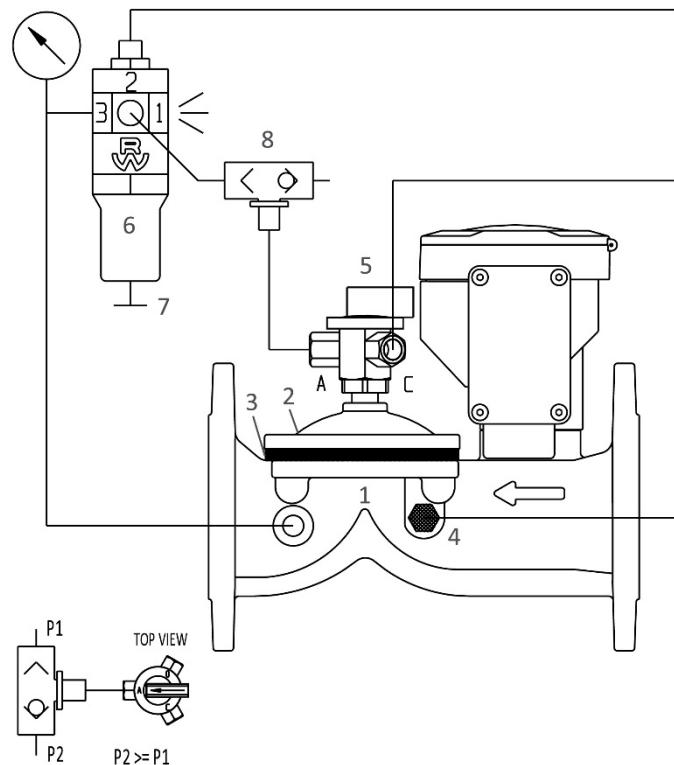

OPERATING INSTRUCTIONS

1. Turn the 3-way selector 5 to the “auto” position.
2. De-pressurize shuttle T 8 from the water pressure source.
3. Make sure that there is a downstream flow demand.
4. Turn adjusting screw 7 on pilot 6 clockwise all the way.
5. Turn adjusting screw 7 counterclockwise, until water will be discharged from the vent of pilot 6 and the Ultraf will start to open.
6. To increase downstream pressure, continue to turn adjusting screw 7 counterclockwise one turn at a time, allowing some time between turns for the Ultraf to respond. Check downstream pressure until required pressure is achieved.
7. To decrease downstream pressure, turn adjusting screw 7 clockwise one turn at a time, allowing some time between turns for the Ultraf to respond. Check downstream pressure until required pressure is achieved.

To manually close the Ultraf, turn the 3 way selector 5 to “close “position.

To manually open the Ultraf, turn the 3 way selector 5 to “open “position.

To operate the Ultraf remotely, turn the 3 way selector 5 to the “auto” position.

To activate the shuttle T 8 and open the Ultraf as PRV, de- pressurize the shuttle T.

To close the Ultraf, re-pressurize the shuttle T.

MAINTENANCE

- Check downstream pressure. Adjust if required.
- No maintenance is required. However, from time to time it is recommended to rotate the 3-way selector 360° to prevent sticking by sediments.
- It is recommended that the Ultraf will be easily accessible as well as clearly marked to prevent damage.
- In freezing climates, the ULTRAF should be dismantled, and water drained during the winter months.

TROUBLESHOOTING ULTRAF 630T

PROBLEM	CAUSE	CHECK	SOLUTION
The ULTRAF does not open.	<ol style="list-style-type: none"> The 3-way selector 5 is in "close" position. The shuttle T 8 is still pressurized. Blocked or stuck shuttle T 8. Blocked pilot valve 6. 	<ol style="list-style-type: none"> Check position. Check the control pressure source and the control tubes. No water venting from the pilot's 6 drain port (1). No water venting from the pilot's 6 drain port (1). 	<ol style="list-style-type: none"> Shift back to "auto" or "open". De-pressurize the shuttle T 8. Turn off water supply to the valve. Dismantle and clean shuttle T ports. Reassemble and activate. Turn off water supply to valve. Dismantle and clean drains in the pilot. Reassemble and activate.
The ULTRAF does not close.	<ol style="list-style-type: none"> The 3-way selector 5 is in "open" position. The shuttle T 8 command port is getting pressure/ pressure not sufficient to close Ultraf. Blocked or stuck shuttle T 8. Foreign object on sealing seat. Blocked self-flushing filter 4. 	<ol style="list-style-type: none"> Check position. Check the control pressure source. Check manual closing option. Poor water flow downstream the Ultraf. 	<ol style="list-style-type: none"> Shift back to "auto". Make sure shuttle T 8 gets same pressure as Ultraf inlet pressure. Turn off water supply to the Ultraf. Dismantle and clean drain connections in the shuttle T. Reassemble and activate. Turn off water supply to the Ultraf. Disassemble cover 2, diaphragm 3 and remove foreign object. Check that diaphragm, body and cover are not damaged. Reassemble and activate. Turn off water supply to the Ultraf. Remove filter to clean or change it. Reassemble and activate
Irregular flow/ pressure.	<ol style="list-style-type: none"> Blocked or damaged pilot 6. 	<ol style="list-style-type: none"> Irregular downstream pressure. 	<ol style="list-style-type: none"> Turn off water supply to the Ultraf. Dismantle and clean pilot's drains. Check state of the membrane. In case of internal parts wear, change pilot. Reassemble and activate.