



# **IOM RAF 60**

Pressure Reducing Control Valve,  
2-way Pilot  
6" - 12"



Jan-24

## DESCRIPTION

This pressure-reducing valve is an automatic control valve designed to reduce a higher upstream pressure into a preset lower downstream pressure, and to maintain this pressure constantly regardless of flowrate or upstream pressure fluctuations.

## INSTALLATION

- Before installing the valve, flush the pipeline to remove scale, dirt and other particles that might affect the valve's performance.
- Install the valve as indicated by the arrow on the valve's cover, showing flow direction.
- It is recommended to install isolation valves (butterfly valves type B8) upstream and downstream the control valve.
- Close 2-way valves # 6 and # 8. Open 2-way valve # 5 and turn on the water supply to the valve.
- Check for leaks; tighten bolts & fittings if necessary.

## PARTS LIST

1. Body
2. Cover
3. Diaphragm
4. Self-Flushing "Finger" Filter
5. 2-Way Valve
6. 2-Way Valve
7. Needle Valve
8. 2-Way Valve
9. 2-Way Pressure Reducing Bronze Pilot P-161
10. Pressure Adjusting Screw

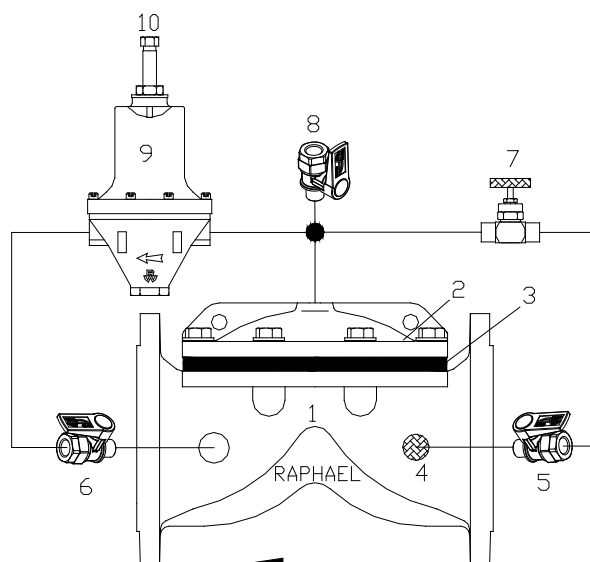

## OPERATING INSTRUCTIONS

---

1. Make sure that there is a downstream flow demand.
2. Close needle valve # 7 all the way and then reopen it for 1-2 turns. The needle valve # 7 adjusts the hydraulic reaction speed. The more the needle valve # 7 is opened the quicker the reaction is. While adjusting the needle valve, please keep in mind that too quick of a reaction may cause a water hammer.
3. Loosen security nut and turn adjusting screw # 10 counterclockwise, so that there is almost no pressure on the pilot's spring.
4. Open 2-way valve # 6.
5. Turn adjusting screw # 10 clockwise, until valve will start to open.
6. To increase downstream pressure, continue to turn adjusting screw # 10 clockwise one (1) turn at a time, allowing some time between turns for the valve to respond. Check downstream pressure until required pressure is achieved. Tighten security nut on the adjusting screw # 10.
7. To decrease downstream pressure, turn adjusting screw # 10 counterclockwise one (1) turn at a time, allowing some time between turns for the valve to respond. Check downstream pressure until required pressure is achieved. Tighten security nut on the adjusting screw # 10.

**To open the valve completely, close the 2-way valves # 5 and # 6 and open 2-way valve # 8. Please note that by so doing the pressure downstream will be as high as the pressure upstream.**

**To close the valve, close 2-way valves # 6 and # 8, and open 2-way valve # 5.**

**To maintain preset pressure, open 2-way valves # 5 and # 6 and close 2-way valve # 8.**

## MAINTENANCE

---

- No maintenance is required.
- Check downstream pressure. Adjust if required.
- It is recommended that the valve be easily accessible as well as clearly marked to prevent damage.
- In freezing climates, the valve should be dismantled, and water drained during the winter months.

## TROUBLESHOOTING RAF 60

PROBLEM	CAUSE	CHECK	SOLUTION
The valve does not open.	<ol style="list-style-type: none"> <li>1. Valve 6 is turned off.</li> <li>2. Blocked water connections.</li> </ol>	<ol style="list-style-type: none"> <li>1. Check state of valve.</li> <li>2. Open valve 8.</li> </ol> <p>WARNING: Maximum high pressure will pass through the valve.</p>	<ol style="list-style-type: none"> <li>1. Open valve 6.</li> <li>2. Turn off water supply to the valve. Dismantle and clean connections in the valve. Reassemble and activate.</li> </ol>
The valve does not close.	<ol style="list-style-type: none"> <li>1. Valve 5 is turned off.</li> <li>2. Valve 8 is open.</li> <li>3. Clogged or stuck needle valve.</li> <li>4. Blocked self-flushing filter.</li> <li>5. Foreign object on seal.</li> </ol>	<ol style="list-style-type: none"> <li>1. Check state of valve.</li> <li>2. Check state of valve.</li> <li>3. Check state of valve.</li> <li>4. Poor downstream water flow.</li> </ol>	<ol style="list-style-type: none"> <li>1. Open valve 5.</li> <li>2. Turn off valve 8.</li> <li>3. Repeat adjustment and operating instructions from a to c.</li> <li>4. Turn off water supply to the valve. Remove filter and clean or replace it if needed. Reassemble and activate.</li> <li>5. Turn off water supply to valve. Remove cover and take away foreign object. Check that diaphragm body and cover are not damaged. Reassemble and activate.</li> </ol>
Unstable pressure	<ol style="list-style-type: none"> <li>1. Needle valve is improperly adjusted.</li> <li>2. Blocked or damaged pilot.</li> <li>3. Blocked water connections.</li> </ol>	<ol style="list-style-type: none"> <li>1. Irregular downstream pressure.</li> <li>2. Irregular downstream pressure.</li> <li>3. Irregular downstream pressure.</li> </ol>	<ol style="list-style-type: none"> <li>1. Repeat adjustment and operation instructions from a to e.</li> <li>2. Turn off water supply to the valve. Dismantle and clean drain connections in pilot. Check that membrane and lower seal are not damaged. Reassemble and activate.</li> <li>3. Turn off water supply to the valve. Dismantle and clean connections. Reassemble and activate.</li> </ol>