



IOM RAF 61

**3-Way Pressure Reducing Control Valve,
Brass Pilot
2" - 12"**



Jan-24

DESCRIPTION

This pressure-reducing valve is an automatic control valve designed to reduce a higher upstream pressure into a preset lower downstream pressure, and to maintain this pressure constantly regardless of flowrate or upstream pressure fluctuations

INSTALLATION

- Before installing the valve, flush the pipeline to remove scale, dirt and other particles that might affect the valve's performance.
- Install the valve as indicated by the arrow on the valve's cover, showing flow direction.
- It is recommended to install isolation valves (butterfly valves type B8) upstream and downstream the control valve.
- Turn the 3-way selector # 5 to the "Close" position and turn on the water supply to the valve.
- Check for leaks; tighten bolts & fittings if necessary.

PARTS LIST

1. Body
2. Cover
3. Diaphragm
4. Self-Flushing "Finger" Filter
5. 2-Way Valve
6. 2-Way Valve
7. Needle Valve
8. 2-Way Valve
9. 2-Way Pressure Reducing Bronze Pilot P-161
10. Pressure Adjusting Screw

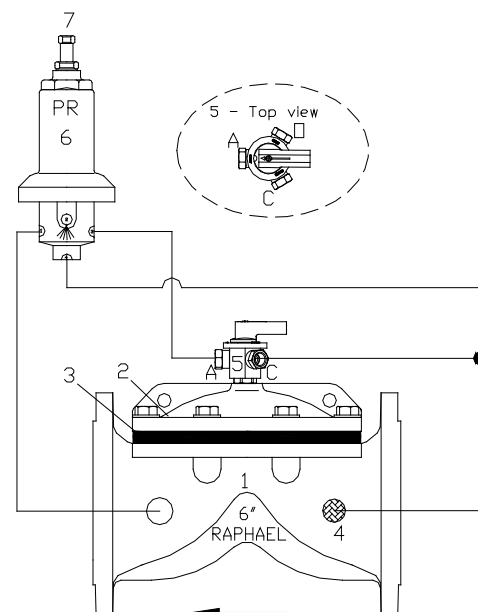

OPERATING INSTRUCTIONS

1. Loosen locking nut on adjusting screw # 7.
 2. Turn adjusting screw # 7 counterclockwise until there is no pressure on the spring.
 3. Make sure that there is a downstream flow demand.
 4. Turn the 3-way selector # 5 to the "Auto" position.
 5. Turn adjusting screw # 7 clockwise, until water will be discharged from port 2 of pilot # 6 and the valve will start to open.
 6. To increase downstream pressure, continue to turn adjusting screw # 7 clockwise one (1) turn at a time, allowing some time between turns for the valve to respond. Check downstream pressure until required pressure is achieved.
 7. To decrease downstream pressure, turn adjusting screw # 7 counterclockwise one (1) turn at a time, allowing some time between turns for the valve to respond. Check downstream pressure until required pressure is achieved.
 8. Tighten locking nut on adjusting screw # 7.
- **To open the valve completely, turn the 3-way selector # 5 to the "Open" position. Please note that by so doing the pressure downstream will be as high as the pressure upstream.**
 - **To close the valve, turn the 3-way selector # 5 to the "Close" position.**
 - **To maintain preset pressure, turn the 3-way selector to the "Auto" position.**

MAINTENANCE

- No maintenance is required. However, from time to time it is recommended to rotate the 3-way selector 360° to prevent sticking by sediments.
- Check downstream pressure. Adjust if required.
- It is recommended that the valve be easily accessible as well as clearly marked to prevent damage.
- In freezing climates, the valve should be dismantled, and water drained during the winter months.

TROUBLESHOOTING RAF 61

PROBLEM	CAUSE	CHECK	SOLUTION
The valve does not open.	<ol style="list-style-type: none"> The 3-Way selector (5) is in the 'Close' position. Blocked pilot. 	<ol style="list-style-type: none"> Check state of valve. No water coming out of drain. 	<ol style="list-style-type: none"> Turn to the 'Open' or 'Auto' position. Turn off water supply to the valve. Dismantle and clean drain connection in pilot. Reassemble and activate.
The valve does not close.	<ol style="list-style-type: none"> The 3-Way selector (5) is in the "Open" position. Foreign object on the sealing seat. Blocked self-flushing filter (4). 	<ol style="list-style-type: none"> Check state of valve. Constant water flow downstream. No water flow from port # 4 on valve. 	<ol style="list-style-type: none"> Turn to the "Auto" or "Close" position. Turn off water supply to the valve. Dismantle the cover and the diaphragm and remove the foreign object. Check that diaphragm body and cover are not damaged. Reassemble and activate. Turn off water supply to the valve. Remove the filter and clean or change it. Reassemble and activate.
Unstable pressure.	<ol style="list-style-type: none"> Blocked or damaged pilot. 	<ol style="list-style-type: none"> Unstable pressure downstream of the valve. 	<ol style="list-style-type: none"> Turn off water supply to the valve. Dismantle and clean drains in pilot. Check membrane. In case of internal parts wear, replace parts. Reassemble and activate.