



IOM RAF 13

Manual Control Valve
Bi-Level float Control Valve
3-Way Float Pilot
1"-16"



May-24

DESCRIPTION

This dual level, modulating, float control valve is an automatic control valve designed to open in full as water level drops and close shut at the levels determined by the float stoppers along a vertical float arm shaft. Minimum and maximum tank levels are adjustable up to 5 m using "add on" shaft spools of 1 m each.

INSTALLATION

- Before installing the valve, flush the pipeline to remove scale, dirt and other particles that might affect the valve's performance.
- Install the valve as indicated by the arrow on the valve's cover, showing flow direction.
- It is recommended to install isolation valves (butterfly valves type B7G) upstream and downstream the control valve.
- It is recommended to place the floats vertical shaft into a 10" PVC protective pipeline and fix it to the tank wall within the water. This will prevent the float from shifting sideways due to water waves.

PARTS LIST

1. Body
2. Cover
3. Diaphragm
4. Self-flushing "Finger" filter
5. Two-way valve
6. 3-way selector valve
7. 3-way float pilot arm shaft
8. Adjustable counterweight
9. Float

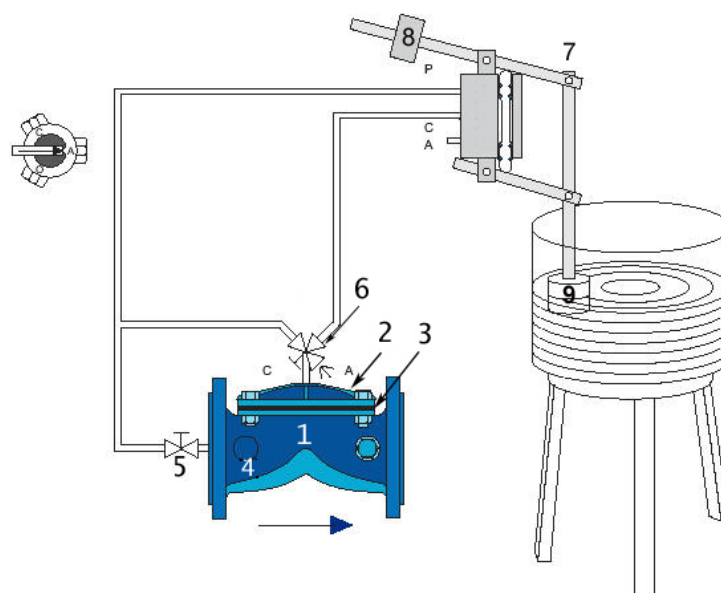

OPERATING INSTRUCTIONS

1. Set float upper stopper to the desired water level **under the float** when the arm shaft is at fully closed (upward) position (Open adjusting bolt along the shaft, set to place and re-tighten). Now let the float arm shaft drop down by its weight and set the lower stopper to the minimum water level allowed (same as for upper stopper). Make sure the float arm is well secured to the tank and will not swing. Use a 10" PVC vertical pipe to guide and secure the float travel by placing the shaft & float into a vertical "peer".
2. Use a 3/8" nylon or copper tube to connect the 1/4" float arm valve # 7 to the 1/8" selector valve # 6. Connect "P" at float pilot with "C" at selector valve and "C" at float with "A" at selector valve.
3. Make sure that there is flow demand from the tank and the float arm shaft # 7 is completely dropped open.
4. Open 2-way valve # 5 and set selector valve to "A". Water will flow freely out of the float pilot vent "A" and the RAF will open fully.
5. Hold the float arm shaft by hand and lift to the close position. A few seconds later the RAF will close drip tight.
6. Drop the float arm, RAF will re-open. Now let the water level rise above the lower stopper. As it rises, so does the float, but without shifting the float pilot upward. Make sure that only when the float reaches the upper stopper it shifts the pilot to close the RAF. As the water level drops again due to usage, the float must travel down freely but the float arm shall stay put in the upper position and the RAF still closed. Adjust the counterweight on the float arm to properly reach that positioning.

MAINTENANCE

- No maintenance is required.
- It is recommended that the valve be easily accessible as well as clearly marked to prevent damage.
- In freezing climates, the valve should be dismantled, and water drained during the winter months.

TROUBLESHOOTING RAF-13

PROBLEM	CAUSE	CHECK	SOLUTION
The RAF does not open.	1. Valve # 6 is turned to C.	1. Check state of valve.	1. Open valve # 6 by turning to A or O.
	2. Blocked water connections.	2. No water is coming out of the float pilot when dropped open.	2. Turn off the water supply to the valve. Dismantle and clean all connections including valve's cover inlet and connecting tub between valve # 6 & float pilot. Reassemble and activate.
	3. The minimal pressure for RAF opening is too low. Keep in mind that the elevated water column from the RAF location to the float location must be added to the minimum pressured required to push the diaphragm open.	3. Check the minimal opening pressure per valve size in the RAF catalogue.	3. Increase pressure as necessary or consult Raphael for a different float pilot type that will vent at valve elevation.
	4. Float pilot is stuck close.	4. Float pilot arm will not shift freely up or down.	4. Turn off water supply to the RAF. Dismantle and clean drain connections in float pilot. Check that the O-rings are not damaged. Grease with silicon grease. Reassemble and activate.
The RAF does not close.	1. Valve # 6 is turned to O.	1. Check state of valve.	1. Shift valve # 6 by turning to A.
	2. Float pilot is stuck open or will not shift position upwards.	2. Float pilot arm will not shift freely up or down.	2/ Turn off water supply to the RAF. Dismantle and clean drain connections in float pilot. Check that the O-rings are not damaged. Grease with silicon grease. Reassemble and activate.
	3. Foreign object on the sealing seat.	3. Constant small water flow downstream.	3/ Turn off water supply to the valve. Remove cover and take away foreign object. Check that diaphragm body and cover are not damaged. Reassemble and activate.
	4. Blocked self-flushing filter.	4/ Raf take very long to close or still leaking while close.	4/ Turn off water supply to the valve. Remove filter. Clean and replace if needed. Clean water connections, reassemble and activate.
The Raf will open / close not at the pre-set water levels.	1. Float pilot is out of balance.	1. When float arm is at close position the float must travel freely up or down by the changing water level w/o shifting the float pilot arm.	1. Adjust counterweight positioning to the proper location that will obtain no change in float pilot arm as the water afloat the float barrel.