

IOM FDV-PP0

PNEUMATIC ACTUATION WITH LOCAL RESET AND PRESSURE REDUCING DELUGE VALVE

Installation **O**peration & **M**aintenance manual

Fire Protection

RAPHAEL VALVES INDUSTRIES

FDV-PP0 – Pneumatic Actuation, Local Reset with Pressure Reducing Deluge Valve

Description

This deluge system is based on the Raphael's FDV valve, equipped with pneumatic actuated control trim. The FDV valve installed, have a range of optional materials and coating to fulfill operation condition needed, but the system function principle stays unchanged: In fire situation, a pneumatic detection system, (a dry pilot line with automatic sprinklers), trips the pneumatic actuators. Consequently, the actuator drains the pressurized water trapped in the FDV's control chamber and the valve opens.



This system is capable to reduce the upstream pressure to a set downstream pressure and maintain it in a steady level. The system responses to any downstream pressure changes caused by consumption flow rate changes and keeps a stable set pressure.

The system is equipped with a PSA, a device that charges manually and locally the Dry pilot pipeline pneumatic pressure, stops automatically the pressurizing during fire situation and compensate pressure loss caused due to minor leakage.

This system is suitable for water spray pipelines with open nozzles.



Part list

1. – Control chamber pressure gauge
2. – MADV manual automatic drain valve
3. – Air supply from compressor – ½” NPT female)
4. – Alarm pressure Switch (optional)
5. – Check Valve
6. – Alarms Test Valve (3 way)
7. – Trim Pressure Supply Valve
8. – “Y” Strainer
9. – MEU Manual Emergence Unit
- 10.– PRPV Pressure Reducing Pilot
- 11.– Downstream pressure gauge
12. – Needle Valve
13. – PAV-2 Pneumatic actuator Valve
- 14.– PSA, Pressure Supply Arrestor
- 15.– PSA port for air supply from compressor – ½” NPT female)
- 16.– Dry pilot connection port – ½” NPT female)
- 17.– Downstream drain valve (1/2” NPT female)
- 18.– Water motor alarm conn. (1/2” NPT female)
- 19.– Upstream Drain port (Plugged).

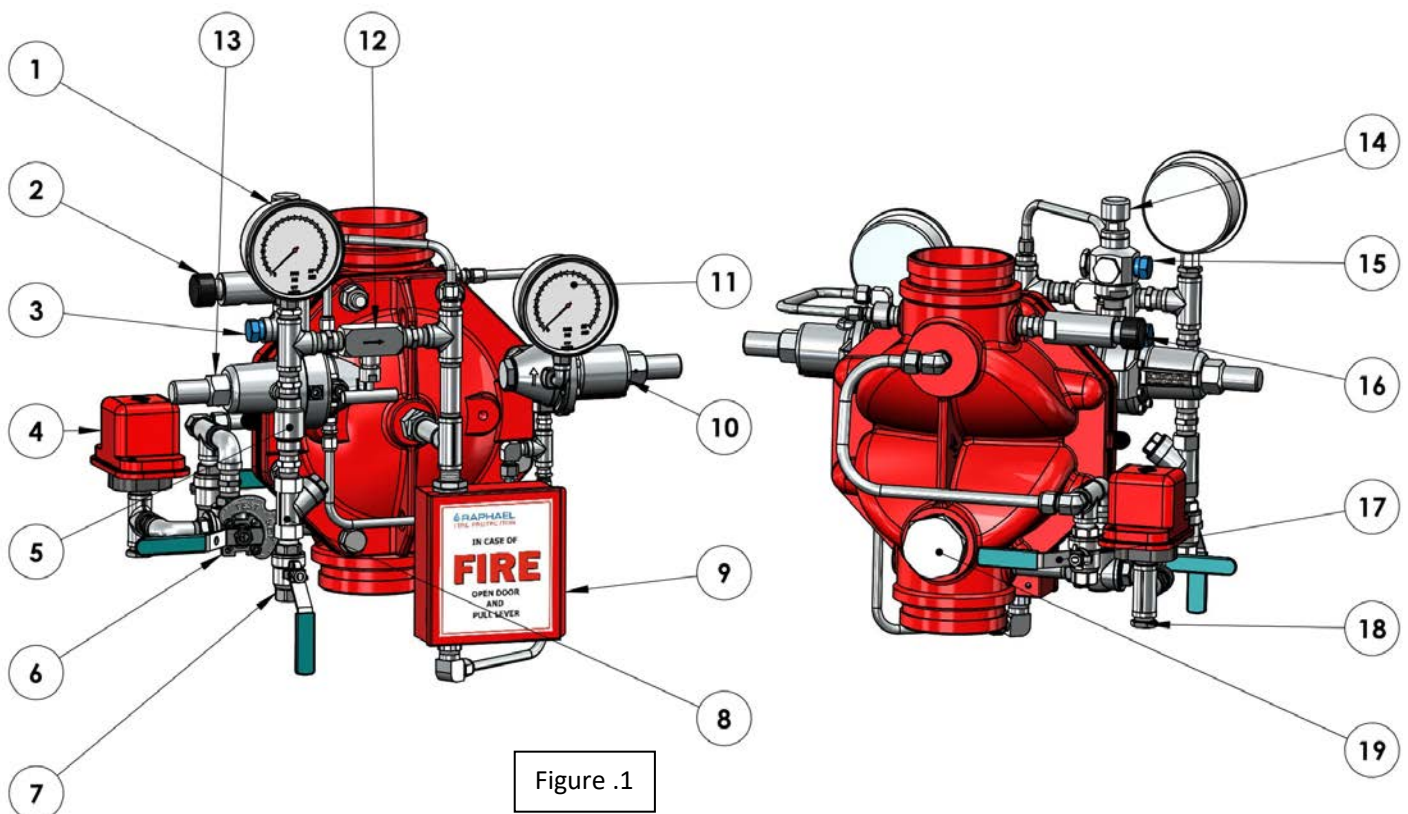

Operation (Reference Figure 1)

SET position:

Water is supplied by the trim supply valve (7), “Y” strainer (8), check valve, flows through the needle valve (12), and fills the FDV’s control chamber. Pressurized water in the valve’s control chamber gets trapped by the check-valve (5), by the PAV-2 actuator (13) and by the closed emergency valve MEU (9), maintaining the deluge valve in closed position. The pressurized air in the dry pilot line holds the PAV-2 actuator in its CLOSE state and consequently, the FDV deluge valve is kept close.

Note: If the pneumatic pressure in the pilot line decreases due to a leakage, the PSA (14) enables the supply pressure to flow into the pilot line and compensate for its pressure loss.

Fire Situation

When one or more of the automatic sprinklers located along the Dry pilot line gets subjected to flames heat and blows-open, the pressurized air vents. The pressure drop in the dry pilot line and in the PAV-2 (13) sense chamber, causes the actuator to OPEN. Water drains from the FDV valve’s control chamber through the PRPV pilot valve (10) to the FDV’s downstream is open.

When the FDV deluge valve opens and water flows into the sprinklers pipeline/s, the PRPV pilot senses the downstream pressure and regulates the FDV’s valve, maintaining a steady downstream preset pressure.

The PSA device blocks any air compensation flow into the dry pipeline enabling it to be fully vented. By that, the PSA serves as a latching device. Opening the MEU (9) door and pulling down the ball valve’s handle, bypasses all terms, drains the FDV control chamber and opens the valve immediately. The downstream pressure is controlled by the PRPV even if the deluge valve was opened manually.

Reset Position

The system reset requires the replacement of all the Dry pilot line’s blown-open automatic sprinklers. This replacement enables pressurizing the dry pilot line initiated by pressing down the PSA’s push button.

pressurizing the dry pilot line causes the PAV-2 to move to its CLOSE state, blocking the FDV’s control chamber drainage while the upstream constantly fills it through the trim’s needle valve. Consequently, the FDV valve closes and the open-nozzles sprinklers spray, stops. By that, the system moved into the SET position.

Drain the sprinklers pipeline by opening the downstream drain ball valve (17) or press the MADV (2) push button.

Installation (Reference Figure 2)

1. This system is supplied pre-assembled and factory pre-adjusted, including the PRPV pilot's set pressure, the needle valve position and the PAV-2 actuator, that is adjusted according to the dry pilot set air pressure. Any change carried out at the system's trim components adjustments or order, pipe and tubes length or ports for axillary connection sizes, will affect the system operation and therefore, prohibited.
2. The system cannot be installed at a location where it might be subjected to freezing temperatures.
3. Sufficient room around the system location should be kept enabling assembly/disassembly and maintenance work.
4. It should be taken into account that water will be drained during regular maintenance on a routine basis, during periodical tests procedures and when operating in fire situation. Therefore, a drainage plan should be considered.
5. The system described, is to be mounted vertically only. Systems with identical operation but for horizontal installation are marked with a prefix "H", e.g. HFDV-PP0.
6. It is essential that the PSA's installation orientation will be vertical only, regardless the deluge valve orientation.
7. The downstream pipe connected to the FDV valve at a horizontal mount, is to be supported firmly to prevent the pipeline's weight to be loaded on the system's valve.
8. Any use of pipe/thread reduction-fittings installed at open ports designated for axillary components, (like water motor alarm, pressure switch, trim pressure supply, Dry pilot pipeline, FDV valve's drains, MADV's and MEU drain ports), is prohibited.
9. All connections to water supply, alarms etc. should be done in accordance with **fig 2**:
 - * (7) – Pressure switch connection port
 - * (6) – Water motor alarm connection
 - * (1) – Trim pressure supply connection
 - * (20) – Air supply from compressor to bottom of PSA (1/2" NPT female)
 - * (20) – Dry pilot line to upper port of PSA (1/2" NPT female)
10. Flow arrow marked on the valve's body, need to be at a proper direction.
11. Remove plastic plugs 1/2" from PSA connection ports.
12. The FDV valve should be installed with the flow arrow marked on the valve's body, in the proper direction.

Installation parts list

(reference - figure 2)

1. Trim supply valve (1/2" NPT female)
2. Y Strainer
3. Alarms test valve (3 way)
4. Needle valve bypass ball valve at the ASK
5. Air supply ball valve at the ASK
6. Water Motor Alarm connection (1/2" NPT female, plugged)
7. Alarm Pressure switch*. (1/2" NPT female connection) *
8. Downstream drain valve
9. PAV-2 Pneumatic Actuator Valve 2 way.
10. MADV manual automatic drain valve
11. Main Control hub
12. Control chamber pressure gauge
13. Dry pilot line
14. Downstream separation valve (butterfly or OS&Y valves).
15. Needle valve
16. Downstream pressure gauge
17. PRPV Pressure Reducing Pilot Valve
18. MEU Manual Emergency Unit
19. Upstream separation valve (butterfly or OS&Y valves).
20. PSA – Pressure Supply Arrestor

*** Optional**

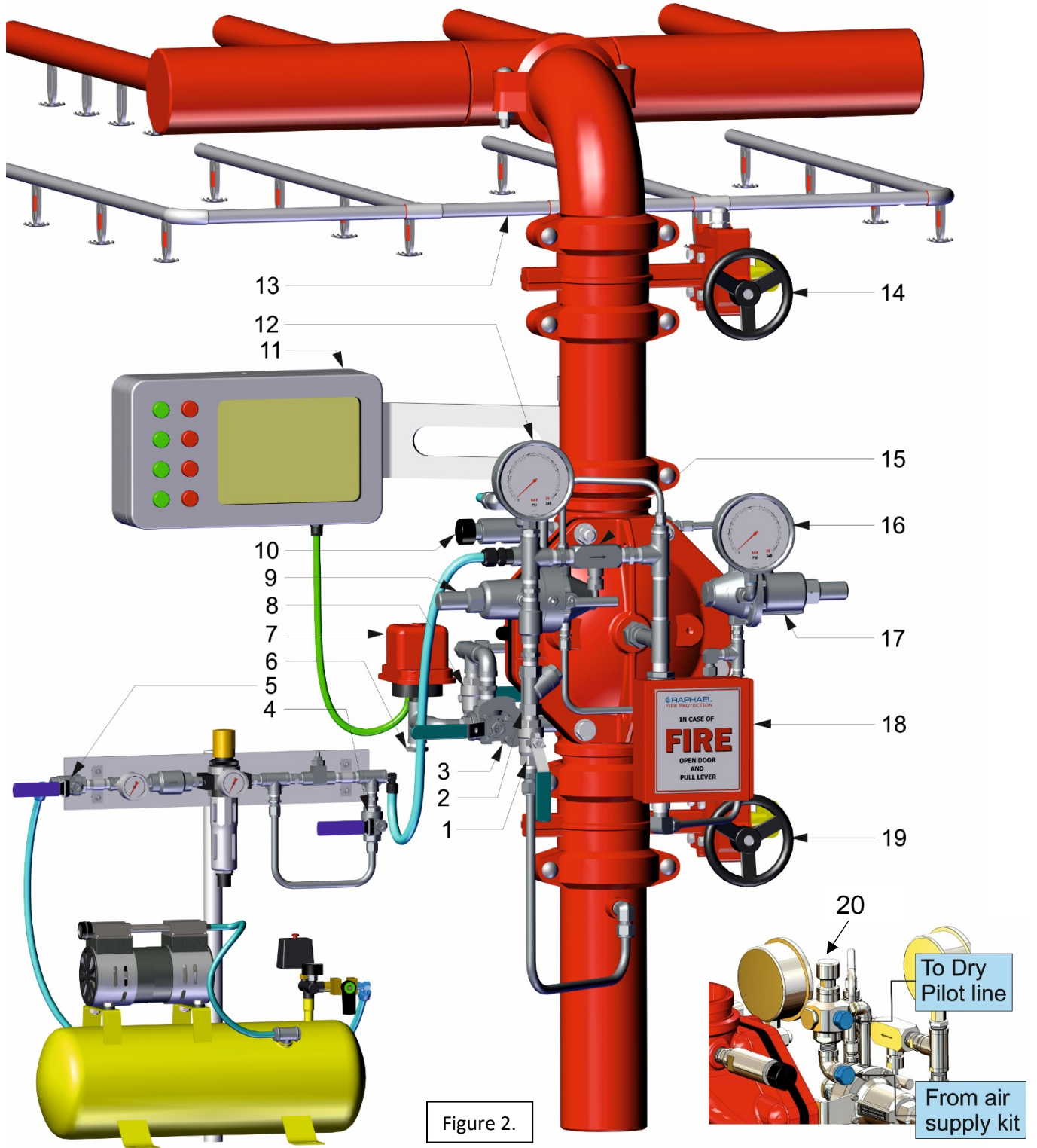

Figure 2.

Operation instruction

Commissioning the system - Phase 1

Filling and pressurizing the system.

The procedure described should be carried out after system installation completion and a comprehensive inspection. (Reference Drawing - figure 2)

1. The filling process needs to be performed only after flushing the pipeline. The flushing needs to be done when both butterfly valves (**19 & 14**) are open, and the trim supply valve (**1**) is close.
2. After flushing, close the upstream butterfly valve (**19**).
3. Make sure the trim pressure supply ball valve (**1**) is closed.
4. Make sure that the Emergency valve in the MEU (**18**) is fully closed.
5. Open ASK air supply ball valve (**5**) and the needle valve bypass ball valve (**4**). Press the PSA (**20**) push button and pressurize the pilot line to the rated set pressure. No adjustments at the PAV-2 (**9**) actuator are needed as the device is factory set. When reached to set pressure, close the needle bypass ball valve (**4**).
6. Close downstream separation butterfly valve (**14**) and open the FDV's downstream drain valve (**8**). The Upstream drain remains plugged, or its valve (if equipped) is close.
7. Open the trim pressure supply valve (**1**) and fill the trim and FDV's control chamber.
8. Open gradually the upstream butterfly valve (**19**).
9. Observe the downstream drain valve (**8**): there should be no leakage or dripping. Leave this ball valve open

The system is ready for the **“fire situation simulation”**.

Commissioning the system - Phase 2

Fire Situation Simulation (Reference Drawing - figure 2)

The procedure described, should be carried out after the system was pressurized and a comprehensive leakage inspection was commissioned.

Energizing the solenoid can simulate a fire situation and cause the system to response by opening the FDV deluge valve.

NOTICE:

Prior to any stoppage of the fire protection system, a fire patrol should be placed in the area covered by the interrupted system.

Prior to generating any test procedures, turning on false alarms or turning off the alarm system, the local safety personnel and the close central fire station must be reported.

(Reference drawing - figure 2)

1. Make sure the downstream separation valve (14) is close and make sure that the downstream drain valve (8) is open.
2. Open the inspector's valve (at the end of the dry pilot line – not illustrated) and vent the pilot line. The pilot's pressure drop will cause the PAV-2 (9) actuator to open and consequently, the FDV deluge valve will open.
3. **Downstream set pressure adjustment:**
Observe the pressure gauge installed on the PRPV pilot valve (17). Downstream set pressure correction if needed, need to be performed following this method -
 - * **Release the small hexagon M4 socket screw located at the adjusting screw cover about two turns using 2mm Allen key and fully unscrew the cover.**
 - * **Unscrew the locking nut on the pilot's adjusting screw about two turns using a 17mm (11/16") wrench.**
 - * **Use a 10mm wrench for the adjusting screw following the procedure below:**
 - **to increase the pressure – turn the pilot's adjusting screw clockwise**
 - **to decrease the pressure – turn the pilot's adjusting screw anticlockwise****after adjustment completion, tighten the locking nut (while holding the adjusting screw in place). Re-install the cover and tighten the M4 screw lock screw.**
4. When downstream pressure was adjusted, close partly and gradually the downstream drain valve (8). Observe the downstream pressure gauge and make sure that the PRPV pilot keeps set pressure steady.
5. Close the inspector's valve at the end of dry pilot line (13) and press down the PSA (20) push button until the line gets pressurized to air set pressure. The process can be expedited by temporarily opening the needle valve bypass ball valve (4) at the ASK (Air Supply Kit). When reached to set pressure, release the push button and close bypass ball valve (4). The FDV deluge valve need to close.

System is ready for re-setting and placing in service.

Commissioning the system - phase 3.

Resetting & placing in service (Reference Drawing - figure 2)

The procedure described, should be carried out after any periodic operational test - simulated or real fire situation. After a real fire situation, replace all blown-open sprinklers before pressurizing the pilot line.

Resetting after a Fire Situation Simulation:

1. Close the Upstream Butterfly valve (19)
2. Close the trim pressure supply (1).
3. Close the inspector's valve (at the end of dry pilot line 13).
4. Press the PSA (20) and make sure the dry pilot line becomes pressurized to set pressure. The process can be expedited by temporarily opening the needle valve bypass ball valve (4) at the ASK. When reached to air set pressure, release the PSA push-button and close ball valve (4).
5. Disassemble the "Y" strainer (2) and clean its screen. Re-assemble the strainer.
6. Open the pressure supply valve (1).
7. Open the Upstream Butterfly valve (19) and observe the downstream drain valve - make sure there is no leakage or dripping. If ok, close this valve.
8. Close the downstream butterfly valve (14)

Resetting after a Real Fire Situation:

1. Close the Upstream Butterfly valve (19)
2. Close the trim pressure supply (1).
3. Close the air supply ball valve at the ASK (5)
4. All the Dry pilot line's blown-open sprinklers must be replaced. When done. Open the air supply ball valve (5) and needle ball valve bypass valve (4). Press the PSA (20) and make sure the dry pilot line becomes pressurized to set pressure. The process can be expedited by temporarily opening the needle valve bypass ball valve (4) at the ASK. When reached to air set pressure, release the PSA push-button and close ball valve (4).
5. Follow steps 5 to 7 listed above under ***Resetting after a Fire Situation Simulation instruction.***

System is in SET state and placed in service.

Maintenance

Prior to any stoppage of the fire protection system, a fire patrol should be placed in the area covered by the interrupted system.

Prior to generating any test procedures, turning on false alarms or turning off the alarm system, the local safety personal and the close central fire station must be notified.

The Maintenance and inspection procedures are based on the relevant chapters at the NFPA 25.

Daily Inspection

Make sure that the deluge valve's heating system (If equipped), functions correctly and that the Fire protection valve surrounding temperature is 4°C min.

Monthly Inspection

1. Observe the FDV deluge valve and its trim for external damage: observe the trim piping and hose connections for leakage or damage.
2. Verify that the upstream and downstream separation butterfly valves (**19 & 13**) and the Trim pressure supply valve (**1**) are in fully open position.
Downstream drain valve (**8**) and upstream drain valve (if equipped) are fully close.
3. Press the PSA push button (**20**) about 5-10 seconds and release. Observe the dry pilot pipeline pressure gauge for set pressure.
4. Make sure that the required supply water pressure is applied to the deluge Valve inlet and trim.
5. Push the MADV (MB) (**10**) and make sure that after emptying condensing water, the drain flow/dripping stops. If a constant leakage is observed, it might indicate a deluge valve sealing problem.
6. Move the 3-way SET/TEST valve handle (**3**) to TEST. The acoustic alarm should sound, and the alarm pressure switch (**7**) should transmit a signal to the main control board. If ok, move the valve's handle to the SET state.

Annual test procedure

1. Conduct the monthly test & inspection procedure.
2. Perform the procedure described in chapter - **Commissioning the system - phase 2.** - Fire Situation Simulation. Check the system's proper operation.
3. Follow the procedure described in chapter - **Commissioning the system - phase 3.** - Resetting & placing in service, chapter **Resetting after a Fire Situation Simulation.**

Every 5 years inspection procedure

This major inspection and maintenance procedure includes the removal of the trim, the dismantling of the FDV's valve cover and a performance of a comprehensive internal part examination. Then, the relevant trim accessories should be replaced, After the completion, the Annual maintenance procedure is to be conducted.

1. Close the upstream butterfly valve (19) and the trim pressure supply valve (1).
2. Open the drain valve (8) and the upstream drain valve if equipped. Drain the FDV's control chamber using the MEU Emergency valve (18).
3. Turn off or disconnect all relevant electrical circuits (alarm pressure switch 7).
4. Release all relevant tubes, fitting nuts and the central union pipe connection (if equipped) at valves cover centre.
5. Remove and disassembled front trim.
6. Remove all the FDV's cover bolts. The cover will hang on its studs (4" DN100 valve size and up). Release both nuts and remove the cover carefully.
7. Observer the internals of the valve and cover for excessive scale residuals, foreign particles, damaged coating (rust, cracks, or peeling).
8. Worn or damaged parts should be replaced. Consult Raphael's local representative or the service department for any maintenance issue or part replacement issue.

9. Replace the Diaphragm. The identification tongue should point to the valve's stamped size side (from top view – at the left side).
10. Reinstall the valve's cover: use the Anti-seize paste supplied in the maintenance kit for bolts and nuts pre-installation lubrication. Tight it in accordance with "**Bolt's torque moments table**".
11. Reinstall the front trim carefully: avoid causing twists or dents on bent tubes and do not overtight the compression fitting's nuts.
12. When the system is fully re-assembled, perform the "**Commissioning the system - phase 1** - Filling and pressurizing the system" procedure.
13. Perform the **Annual test procedure**.

Bolt's Torque Moments Table

Valve size	1.5"	2"	2.5"	3"	4"	6"	8"	10"
Torque lb/ft	22	29	36	54	65	72	87	118

Equivalent pipe length for FDV deluge valves

Valve size	Equivalent length value ft (m)
1.5"	11 (3.6)
2"	24 (7.3)
2.5"	25 (7.6)
3"	28 (8.5)
4"	31 (9.4)
6"	46 (14)
8"	72 (21.9)
10"	117 (35.6)

Marking

The FDV valves are marked by a laser engraved, black anodized, 0.8mm (0.031") thick metal plate, riveted to the valve's cover.

- *Company name and trademark.*
- *Short description (Italic letters)*
- *Application's type:* FDV-PP0 – Pneumatic actuated, Local Reset with Pressure Reducing.
- *(P/N) The Application's part number.* System properties–Valve properties
- *Rated pressure:* 250 psi
- *Equivalent Length:* reference table - page 12.
- *Serial Number:* Work order number-MM-YY-Number in batch 01-99
- *The UL listing mark & QR code:* EXxxxxx
- *The FM approved mark*
- *The Application's diameter in inch: XX"*

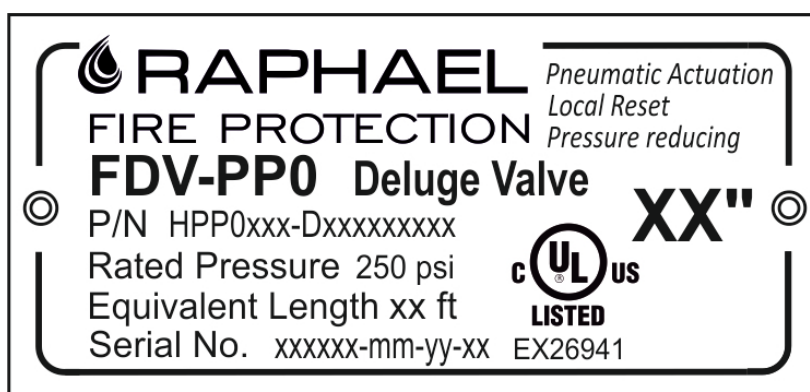

**Pneumatically actuated, Local Reset FDV deluge valve,
With Pressure Reducing, Type: FDV-PP0**

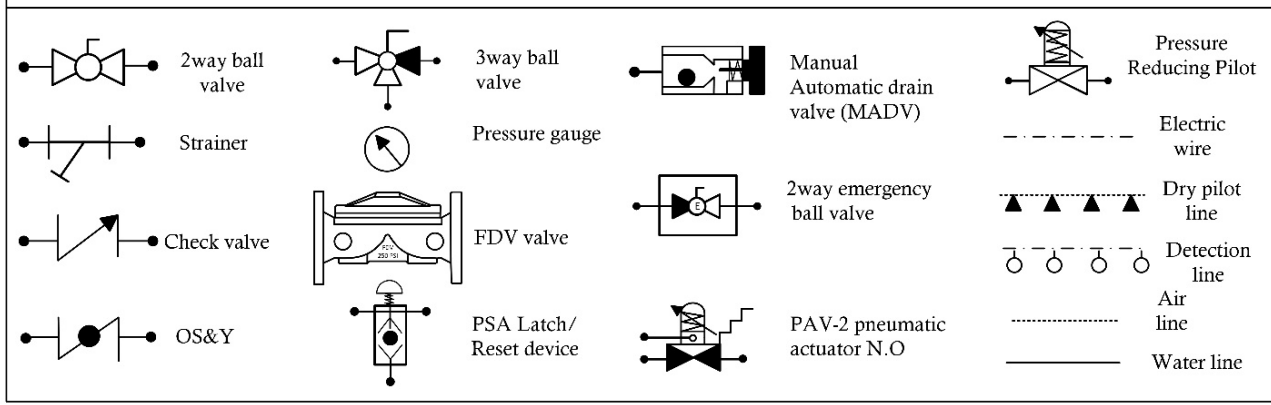
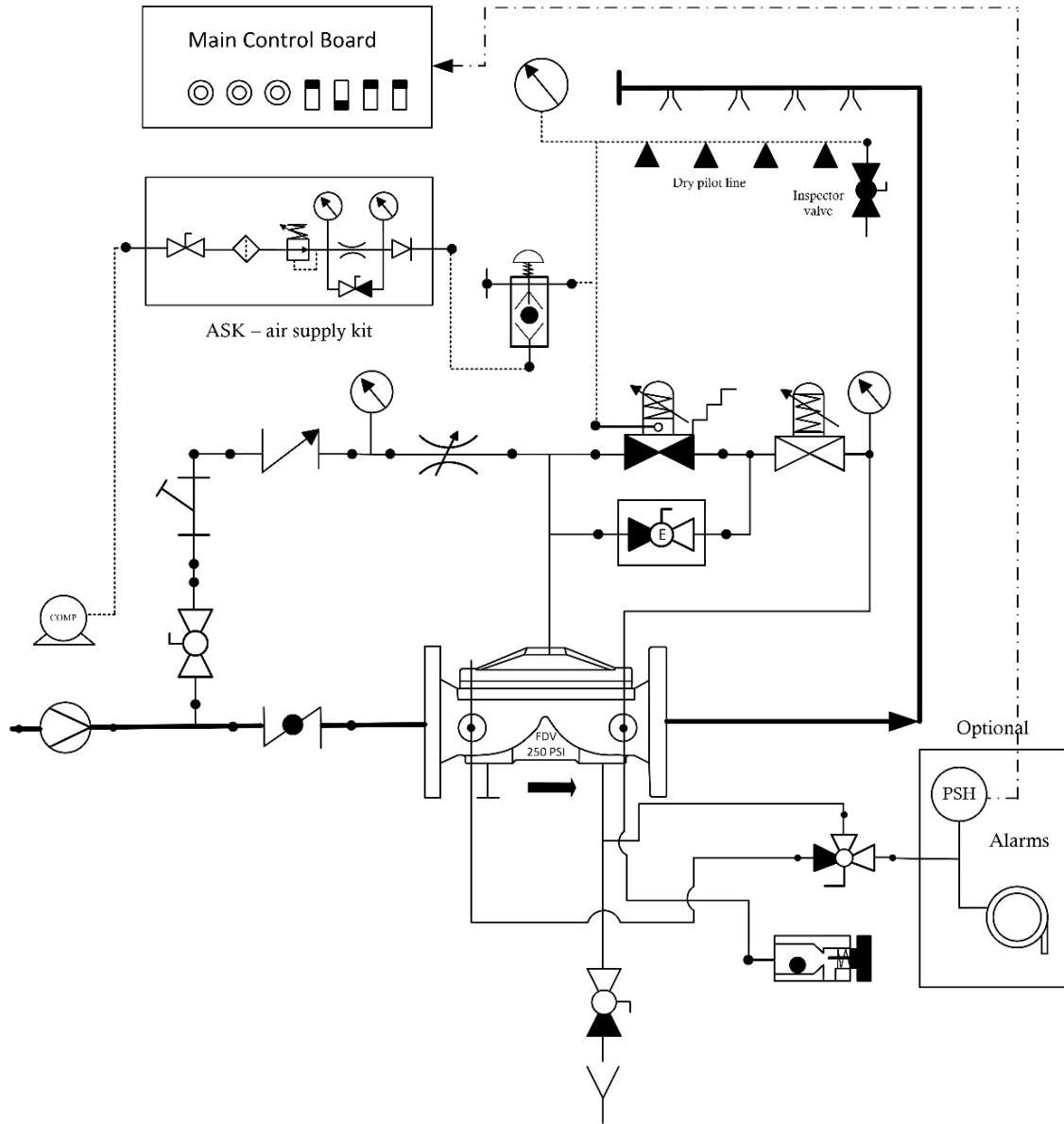

RAPHAEL, founded in 1949, is the first Israeli manufacturer of water control valves. RAPHAEL 's research department constantly strives to introduce new and innovative products and solutions for water control systems including water works, fire-protection and irrigation systems.



Waterworks



Fire Protection



Irrigation



Smart Solutions



RAPHAEL Valves Industries (1975) Ltd.

North Industrial Zone Or Akiva, 3063927 P.O.Box 555, Israel

Tel. +972 4 6263555 | info@raphael-valves.com | raphael-valves.com