

IOM FDV-PH0

HYDRAULIC ACTUATION WITH LOCAL RESET AND PRESSURE REDUCING DELUGE VALVE

Installation **O**peration & **M**aintenance manual

Fire Protection

RAPHAEL VALVES INDUSTRIES

FDV-PH0 – Hydraulic Actuation, Local Reset Pressure reducing Deluge Valve

Description

system is based on the Raphael's FDV valve, equipped with hydraulic actuated control trim. The FDV valve installed, have a range of optional materials and coating to fulfill operation condition needed, but the system function principle stays unchanged: in fire situation, a hydraulic detection system, (a wet pilot line with automatic sprinklers), trips the hydraulic actuator. Consequently, this actuator drains the pressurized water trapped in the FDV's control chamber and the valve opens.

This system is capable to reduce the upstream pressure to a set downstream pressure and maintain it in a steady level. The system responses to any downstream pressure changes caused by consumption flow rate changes and keeps a stable set pressure.

The trim is equipped with a PSA – a device that enables the local reset of the system i.e. closing the FDV valve by pressurizing the valve's control chamber. In addition, the PSA serves as a latching device that keeps the deluge valve open in all terms. The system is suitable for water spray pipelines with open nozzles.



Parts List

- | | |
|--|---|
| <ul style="list-style-type: none"> 1. – Downstream pressure gauge 2. – PRPV Pressure reducing pilot 3. – Pressure switch (optional) 4. – Downstream drain valve 5. – Alarm test valve (3 way) 6. – Check valve 7. – “Y” Strainer 8. – Trim Pressure Supply Valve 9. – PSA – Pressure Supply Arrestor 10.– Needle valve | <ul style="list-style-type: none"> 11.– MEU Manuel emergency unit 12. – Wet pilot’s conn. Port (1/2” NPT female temporary plugged) 13.– MADV (MB) drain valve 14.– HAV-2 hydraulic actuator 15.– Upstream drain (Plugged) 16.– Water motor alarm conn. (1/2” NPT female). |
|--|---|

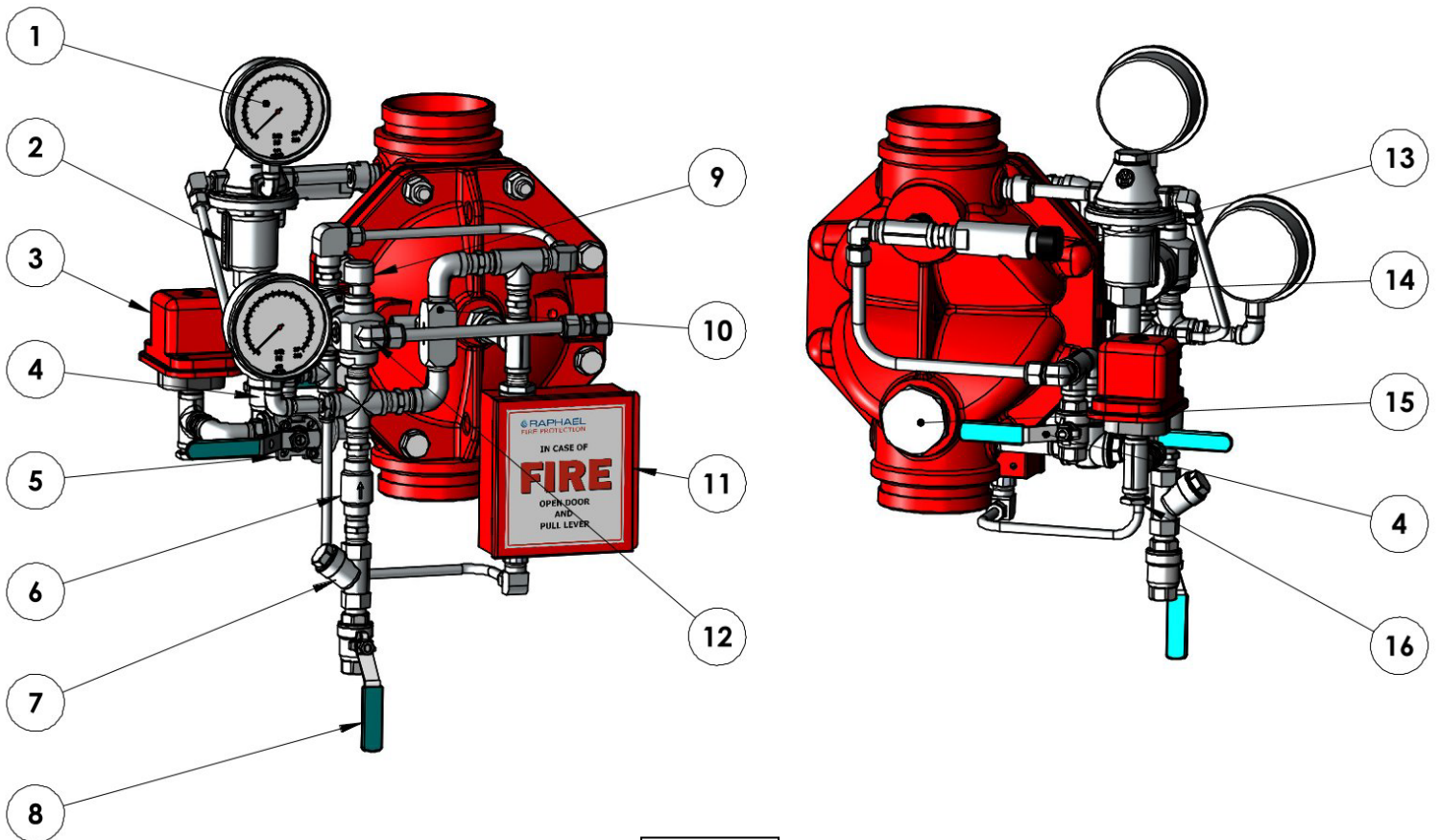

Figure .1

Operation (Reference Figure 1)

SET position:

The trim is supplied by the trim supply valve (8), "Y" strainer (7), check valve (6), flows through the needle valve (10) and fills the FDV's control chamber. Pressurized water in the valve's control chamber gets trapped by the check-valve (6), by the HAV-2 actuator and by the closed emergency valve MEU (11), maintaining the deluge valve in closed position.

The pressurized water in the Wet pilot line connected to HAV-2's control chamber (14), (through the upper manifold of the PSA - 9), holds it in its close state.

In case of minor leakage from the FDV's control chamber piping, the PSA (9) moves to its 'compensation state', ensuring the valve remains close.

Fire Situation

When one or more of the automatic sprinklers located along the pressurized Wet pilot line gets subjected to flames heat / smoke and shatters open, it depressurizes. The pressure drop in the wet pilot line, causes the HAV-2 to move to its open state, draining The FDV deluge valve's control chamber through the pressure reducing pilot valve – PRPV (2).

The opened FDV valve admits water into the sprinklers pipeline/s. The PRPV pilot senses the downstream pressure and regulates the FDV's valve, maintaining a steady downstream preset pressure.

Opening the MEU (11) door and pulling down the ball valve's handle, drains the FDV control chamber, bypasses all terms, and opens the valve immediately.

Reset Position

Resetting this system requires the replacement of all Wet pilot line's shattered open automatic sprinklers. This replacement enables the manual pressurizing (performed by pressing down the PSA (9) push bottom.

When the wet pilot line is pressurized the HAV-2 moves to its close state, blocking the FDV deluge control chamber drainage, while the upstream fills it constantly through the trim's needle valve. Consequently, the FDV valve closes and the open nozzles spray, stops.

By that, the system moved into the SET position. The sprinklers pipeline should be drained by opening the FDV downstream drain port's ball valve (6 figure 2) or by pressing down the MADV (13) push bottom.

Installation (Reference Figure 2)

1. This system is supplied pre-assembled and factory pre-adjusted. Any change carried out at the system's trim components order, pipes and tubes length or ports for axillary connection sizes, will affect the system operation and therefore, prohibited.
2. The system cannot be installed at a location where it might be subjected to freezing temperatures.
3. maintaining sufficient room around the system location ensures operational safety, and ease of maintenance.
4. It should be considered that water will be drained during regular maintenance on a routine base, during periodical tests procedures and when operating in fire situation. Therefore, a drainage plan should be considered.
5. The system described is to be mounted vertically only. Systems with identical operation but for horizontal installation are marked with a prefix "H", e.g. HFDV-PH0.
6. The downstream pipe connected to the FDV valve at Vertical and horizontal mount system, is to be supported firmly to prevent the pipeline's weight to be loaded on the system's valve.
7. Any use of pipe/thread reduction-fittings installed at open ports designated for axillary components, (like water motor alarm, trim pressure supply, FDV valve's drains), is prohibited.
8. All connections to water supply, should be done in accordance with figure 2
 - (1) – Trim pressure supply connection - 1/2" NPT female.
 - (5) – Alarm gong to alarm test valve - 1/2" NPT female.
 - (12 Fig 1) – wet pilot line (optional) connection – 1/2" NPT female (plugged).
 - (7) Pressure switch (optional) connection - 1/2" NPT female (plugged).
9. The FDV valve should be installed with the flow arrow marked on the valve's body, in the proper direction.

FDV-PH0 – Hydraulic Actuated with Local Reset and Pressure Reducing Deluge Valve.

Installation parts list.

(reference - figure 2)

1. Trim pressure supply valve (1/2" NPT female).
2. "Y" Strainer.
3. Check valve
4. 3-way alarm test valve. (plugged).
5. Water Motor Alarm * connection (1/2" NPT female,
6. Downstream drain valve (1/2" NPT female).
7. Pressure switch *. (1/2" NPT female connection).
8. Upstream pressure gauge.
9. PRPV Pressure Reducing Pilot Valve
10. Downstream pressure gauge.
11. Main control board **.
12. MADV-(MB). Manual Automatic Drain Valve.
13. Wet pilot line.
14. Downstream separation valve (butterfly or OS&Y valves) **.
15. PSA – Pressure Supply Arrestor
16. Needle valve
17. MEU - Manual Emergency Unit.
18. Upstream separation valve (butterfly or OS&Y valves) **.

*** Optional**

**** Out of scop of supply**

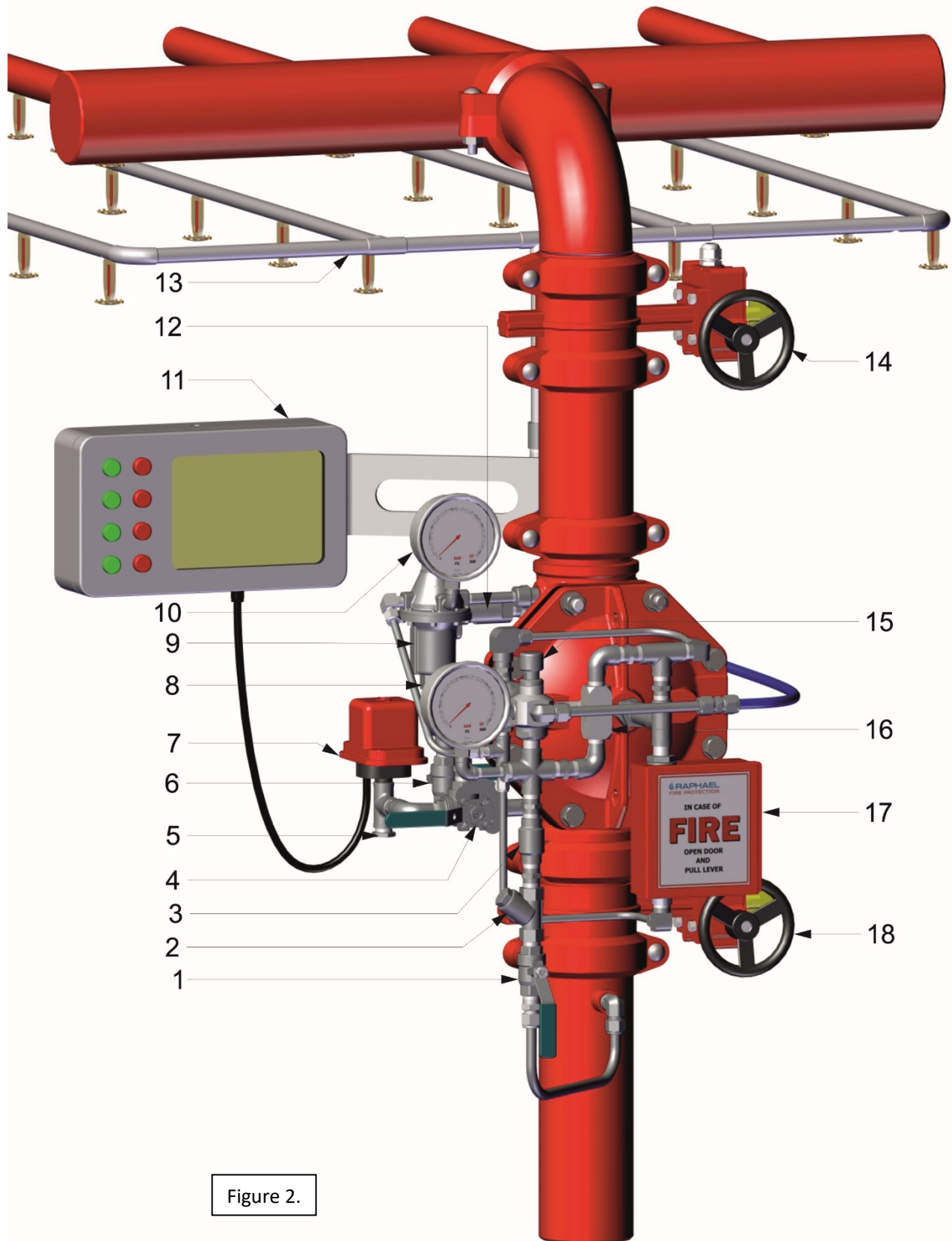

Figure 2.

Commissioning the system - Phase 1

Filling and pressurizing the system.

The procedure described should be carried out after system installation completion and a comprehensive inspection. (Reference Drawing - figure 2)

1. The filling process is performed only after flushing the pipeline. The flushing needs to be done when both butterfly valves (**14 & 18**) are open, and the trim supply valve (**1**) is closed.
2. Close the upstream butterfly valve (**18**).
3. Make sure the trim pressure supply ball valve (**1**) remains closed.
4. Make sure that Emergency valve at the EMU (**17**) is fully closed.
5. Open the FDV's downstream drain valve (**6**) and make sure the upstream drain valve if equipped is closed or port is plugged.
6. Open the inspector's valve located at the very end of the wet pilot's pipeline (**13**).
7. Open the trim pressure supply valve (**1**).
8. Press the PSA's push-button (**15**). Let water flow out of the inspector's valve until a clear flow, free of air bubbles is observed.
9. Close the inspector's valve and pressurize the Wet pilot pipe: hold the PSA's push-button (**15**) and charge pilot's pipeline to set pressure.
10. Make sure the FDV's downstream drain valve (**6**) is open and upstream drain valve if equipped, is close.
11. Open gradually the upstream butterfly valve and make sure the downstream drain valve (**6**) is not dripping. If a dripping accurses, it might indicate a FDV valve sealing issue.
12. Close the Downstream drain valve (**6**).

The system is ready for the "fire situation simulation".

Commissioning the system - Phase 2

Fire Situation Simulation (Reference Drawing - figure 2)

The procedure described, should be carried out after the system was pressurized and a comprehensive leakage inspection was commissioned. Energizing the solenoid can simulate a fire situation and cause the system to response by opening the FDV deluge valve.

NOTICE:

Prior to any stoppage of the fire protection system, a fire patrol should be placed in the area covered by the interrupted system.

Prior to generating any test procedures, turning on false alarms or turning off the alarm system, the local safety personnel and the close central fire station must be reported.

1. Open the inspector's valve at the wet pilot pipeline's end. Trapped pressure will escape and the HAV-2 actuator will open and drain the FDV deluge control chamber causing it to open.
2. Observe the pressure gauge installed on the PRPV pilot valve (**10**). Downstream set pressure correction if needed, is performed by this method:
release the small M4 socket screw located at the adjusting screw cover about two turns and remove the cover.
 - to increase the pressure – turn the pilot's adjusting screw clockwise
 - to decrease the pressure – turn the pilot's adjusting screw anti-clockwiseafter adjustment completion, re-install the cover and tighten the M4 screw, to lock the cover.
3. Assure the functionality of the PRPV pilot valve and the downstream pressure steadiness: While the FDV valve is open, turn the downstream drain valve handle and open the valve. Wait until the pressure reaches to SET. Then, gradually close this ball valve. Observe the downstream gauge reading - it should reach again to SET pressure

The system is ready for re-setting and placing in service.

Commissioning the system - phase 3.

Resetting & placing in service (Reference Drawing - figure 2)

The procedure described, should be carried out after any periodic operational test - simulated or real fire situation. After a real fire situation, replace all blown-open sprinklers before pressurizing the pilot line.

Resetting after a Fire Situation Simulation:

1. Close the Upstream Butterfly valve **(18)**
2. Close the trim pressure supply **(1)**.
3. Close the inspector's valve (at the end of wet pilot line **10**).
4. Disassemble the "Y" strainer **(2)** and clean its screen. Re-assemble the strainer.
5. Open the trim pressure supply valve **(1)**. Push the PSA **(13)** push button until both pressure gauges **7 & 6** show the same reading.
6. The Upstream Butterfly valve **(3)** and the downstream butterfly valve **(7)** should be opened gradually. There should be no flow and no dripping through the downstream drain valve **(5)**. If ok, close this valve.

Resetting after a Real Fire Situation:

1. Close the Upstream Butterfly valve **(16)**
2. Close the trim pressure supply **(1)**.
3. Close the inspector's valve (at the end of wet pilot line **13**).
4. All the Dry pilot line's blown-open sprinklers need to be replaced **(13)**.
5. Disassemble the "Y" strainer **(2)** and clean its screen. Re-assemble the strainer.
6. Open the trim pressure supply valve **(1)**. Push the PSA **(15)** push button until both pressure gauges **8 & 10** show the same reading.
7. The Upstream Butterfly valve **(18)** and the downstream butterfly valve **(14)** should be opened gradually. There should be no flow and no dripping through the downstream drain valve **(6)**. If ok, close this valve.

System is in SET state and placed in service.

Maintenance

Prior to any stoppage of the fire protection system, a fire patrol should be placed in the area covered by the interrupted system.

Prior to generating any test procedures, turning on false alarms or turning off the alarm system, the local safety personal and the close central fire station must be notified.

The Maintenance and inspection procedures are based on the relevant chapters at the NFPA 25.

Daily Inspection

Make sure that the deluge valve's heating system (If equipped), functions correctly and that the Fire protection valve surrounding temperature is 4°C min.

Monthly Inspection

1. Observe the FDV valve for external damage: observe the piping and hose connections for leakage or damage.
2. Verify that the upstream and downstream butterfly valves (**18 & 14**) and the Trim pressure supply valve (**1**) are in fully open. Downstream drain valve (**6**) and upstream drain valve (if equipped) are fully close.
3. Observe the FDV control chamber pressure gauge (**12**) and make sure that its that the required supply water pressure is applied to the deluge Valve inlet and trim.
4. Push the MADV (**12**) and make sure that after emptying condensing water, the drain flow/dripping stops. If a constant leakage is observed, it might indicate a deluge valve sealing problem.
5. Move the 3-way SET/TEST valve (**4**) to TEST. The acoustic alarm should sound, and the alarm pressure switch (**7**) if equipped, should transmit a signal to the main control board.

Annual test procedure

1. Conduct the monthly test & inspection procedure.
2. Perform the procedure described in chapter - **Commissioning the system - phase 2.** - Fire Situation Simulation. Check the system's proper operation.
3. Follow the procedure described in chapter - **Commissioning the system - phase 3.** - Resetting & placing in service, chapter ***Resetting after a Fire Situation Simulation.***

Every 5 years inspection procedure

This major inspection and maintenance procedure includes the removal of the trim, the dismantling of the FDV's valve cover and a performance of a comprehensive internal part examination. Then, the relevant trim accessories should be replaced, After the completion, the Annual maintenance procedure is to be conducted.

1. Close the upstream butterfly valve (**18**) and the trim pressure supply valve (**1**).
2. Open the downstream drain valve (**6**) and the upstream drain valve if equipped. Drain the FDV's control chamber using the EMU Emergency valve (**17**).
3. Turn off and disconnect all relevant electrical circuits (pressure switch cable)
4. Release all relevant tubes fitting nuts and the central union pipe connection (if equipped) at valve's cover center.
5. Remove the disassembled front trim.
6. Remove all the FDV's cover bolts. The cover will hang on its studs. Release both nuts and remove the cover carefully. (relevant to valve size 4" and on)

7. Observe the internals of the valve and cover for excessive scale residuals, foreign particles, damaged coating (rust, cracks, or peeling).
8. Worn or damaged parts should be replaced. Consult Raphael's local representative or the service department for any maintenance issue or part replacement issue.
9. Replace the Diaphragm. The identification tongue should point to the valve's stamped size (diameter in inch) side.
10. Reinstall the valve's cover: use the Anti-seize paste tube supplied in the maintenance kit for bolts and nuts pre-installation lubrication. Tight it in accordance with "**Bolt's torque moments table**".
11. Reinstall the front trim carefully: avoid causing twists or dents on bent tubes and do not overtight the compression fitting's nuts.
12. When the system is fully re-assembled, perform the "**Commissioning the system - phase 1** - Filling and pressurizing the system" procedure.
13. Perform the **Annual test procedure**.

Bolt's Torque Moments Table

Valve size	1.5"	2"	2.5"	3"	4"	6"	8"	10"
Torque lb/ft	22	29	36	54	65	72	87	118

Equivalent pipe length for FDV deluge valves

Valve size	Equivalent length value ft (m)
1.5"	11 (3.6)
2"	24 (7.3)
2.5"	25 (7.6)
3"	28 (8.5)
4"	31 (9.4)
6"	46 (14)
8"	72 (21.9)
10"	117 (35.6)

Marking

The FDV valves are marked by a laser engraved, black anodized, 0.8mm (0.031") thick metal plate, riveted to the valve's cover.

- *Company name and trademark.*
- *Short description (Italic letters)*
- *Application's type:* FDV-PH0 – Hydraulic actuated Local Reset, Pressure reducing.
- *(P/N) The Application's part number.* System properties–Valve properties
- *Rated pressure:* 250 psi
- *Equivalent Length:* reference table - page 12.
- *Serial Number.* Work order number-MM-YY-Number in batch 01-99
- *The UL listing mark & QR code:* EXxxxxx
- *The Application's diameter in inch:* XX"

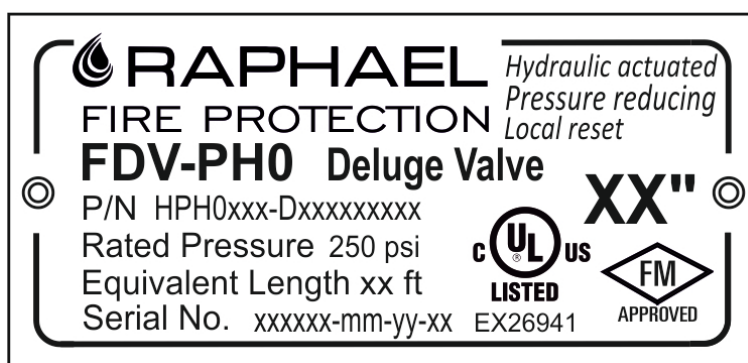

Hydraulic actuation, Local Reset, Pressure Reducing FDV Veluge valve, Type: FDV-PH0

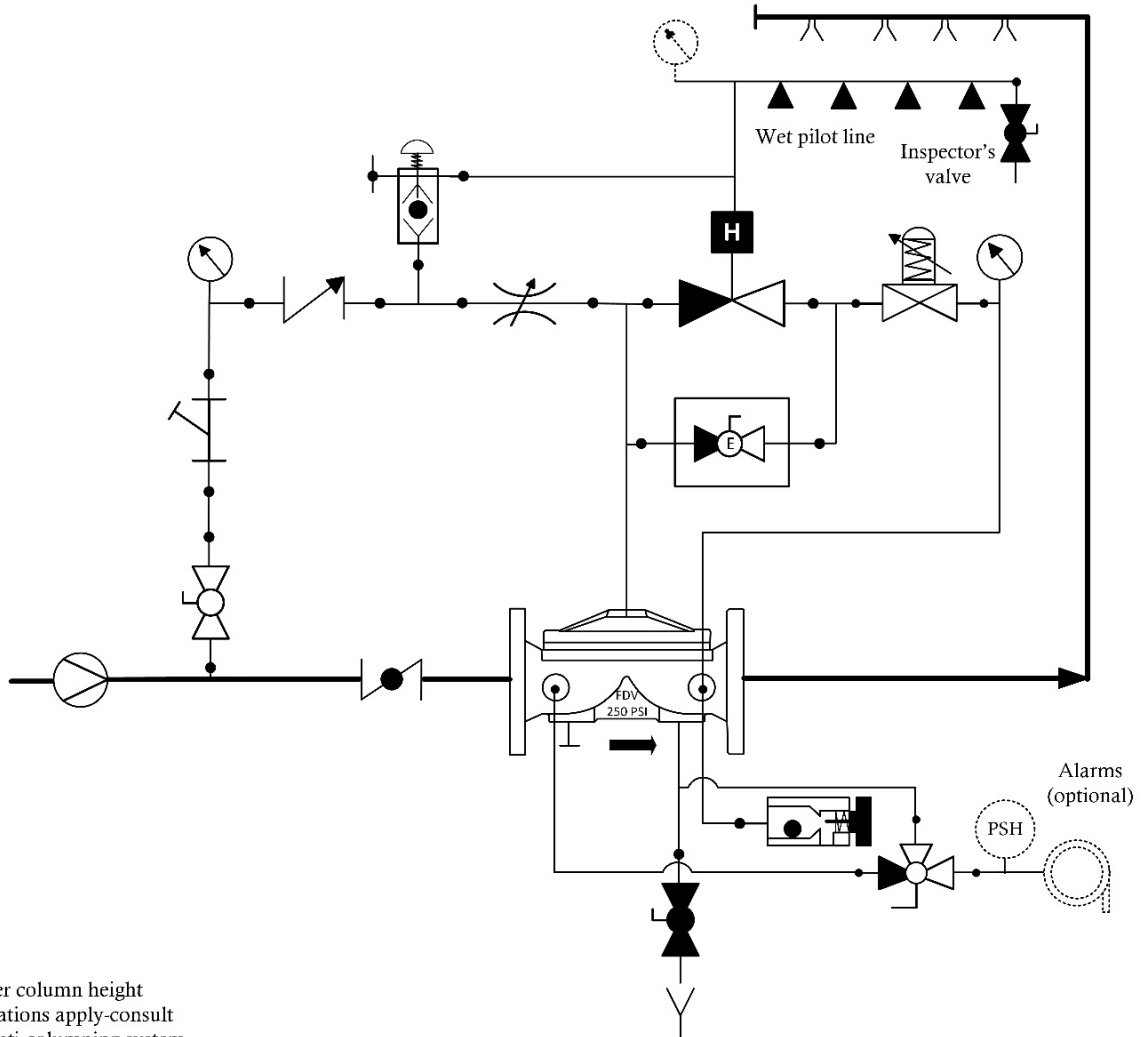

* Water column height limitations apply-consult for anti-columning system FDV-PA0

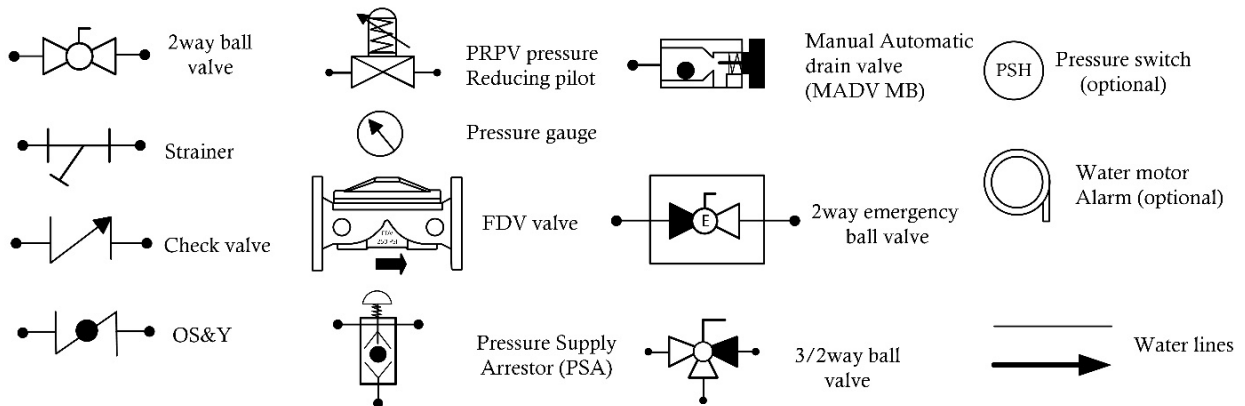

RAPHAEL, founded in 1949, is the first Israeli manufacturer of water control valves. **RAPHAEL** 's research department constantly strives to introduce new and innovative products and solutions for water control systems including water works, fire-protection and irrigation systems.



Waterworks



Fire Protection



Irrigation



Smart Solutions