

IOM FPS-DIE0

Double Interlock, Electric/Electric actuation with Local Reset Preaction system

INSTALLATION OPERATION & MAINTENANCE MANUAL

FIRE PROTECTION

RAPHAEL VALVES INDUSTRIES

Description

The Preaction system is based on a controlled deluge valve and a clapper check valve installed at its downstream. The riser check valve is kept close by the pressurized automatic sprinklers pipeline. The space between the close deluge downstream side and the closed clapper at the riser check valve serves as the “Intermediate chamber” where the acoustic alarm and pressure switch are connected to.

In a fire situation, the flames heat shatters open one or more of the automatic sprinklers causes the pipeline to de-pressurize. The pressure decrease is monitored by the (upper) pressure switch and transmitted to the main control board. This is considered as one event of actuation. When one or more of the smoke detectors is activated, it sends an electric signal to the main control board. This is considered as the second event of actuation. Only when both events of actuation occur, the control board open the SOV and the FDV deluge valve opens, admitting water to the sprinkles pipeline. The system is equipped with the PSA that serves as a hydraulic latching device and is essential for the local reset procedure.



Operation (reference - figure 1)

SET position:

The trim pressure is supplied via ball valve (10), “Y” strainer (9), and fills the FDV’s control chamber. Pressurized water at the valve’s control chamber gets trapped by the check-valve (15), the closed SOV (13) and by the closed emergency valve unit (16), maintaining the deluge valve in closed position.

The sprinkler pipeline is pressurized by the Air Supply Kit through a check valve (2), monitored by the Air/Water pressure gauge (11) and pressure switch (1).

The pneumatic pressure is trapped by the Clapper of the riser check valve, by the closed check valve (2), by the drain-ball-valve (3) and by the automatic sprinklers.

Series of smoke/Heat detectors are installed over the protected area and connected electrically to the main FP control board (13 figure 2).

FIRE situation:

When one or more smoke detectors get alarmed by fire, a signal is transferred to the main fire protection control board.

When the flames heat causes one or more of the automatic sprinkles to shatter and open, the trapped pneumatic pressure drops, the pressure switch (1) transmits a signal to the main control board too. Consequently, the main control board opens the solenoid valve (13) and the FDV’s control chamber drains, causes the Deluge to open.

The hydraulic pressure drop in the FDV’s control chamber causes the internal elastomeric ball in the PSA (5) to be pushed against the upper internal orifice and block it. When blocked, the upstream pressure flow to the FDV control chamber stops and the FDV valve becomes latched open.

Opening the Emergency ball valve, bypasses all terms, drains the FDV control chamber and opens the valve immediately.

RESET position.

The reset procedure is described in detail in page 10, **Commissioning the system - phase 3**.
Resetting & placing in service.

Parts list (reference figure 1)

- | | |
|--|--|
| <ul style="list-style-type: none"> 1. – Air/water pressure switch 2. – Air supply check valve ¼” NPT female 3. – Riser check valve drain ball valve – ½” NPT female 4. – MADV drain valve 5. – PSA Pressure supply arrestor 6. – Upstream pressure gauge 7. – Alarm pressure switch 8. – Set/Test 3 way valve 9. – “Y” Strainer | <ul style="list-style-type: none"> 10. – Trim pressure supply ½” NPT female 11. – Air/water pressure gauge 12. – Riser check valve 13. – SOV solenoid valve 14. – Control chamber pressure gauge. 15. – Check Valve 16. – MEU emergency unit 17. - Upstream drain (plugged) 18. - Water motor alarm conn. ½” NPT female |
|--|--|

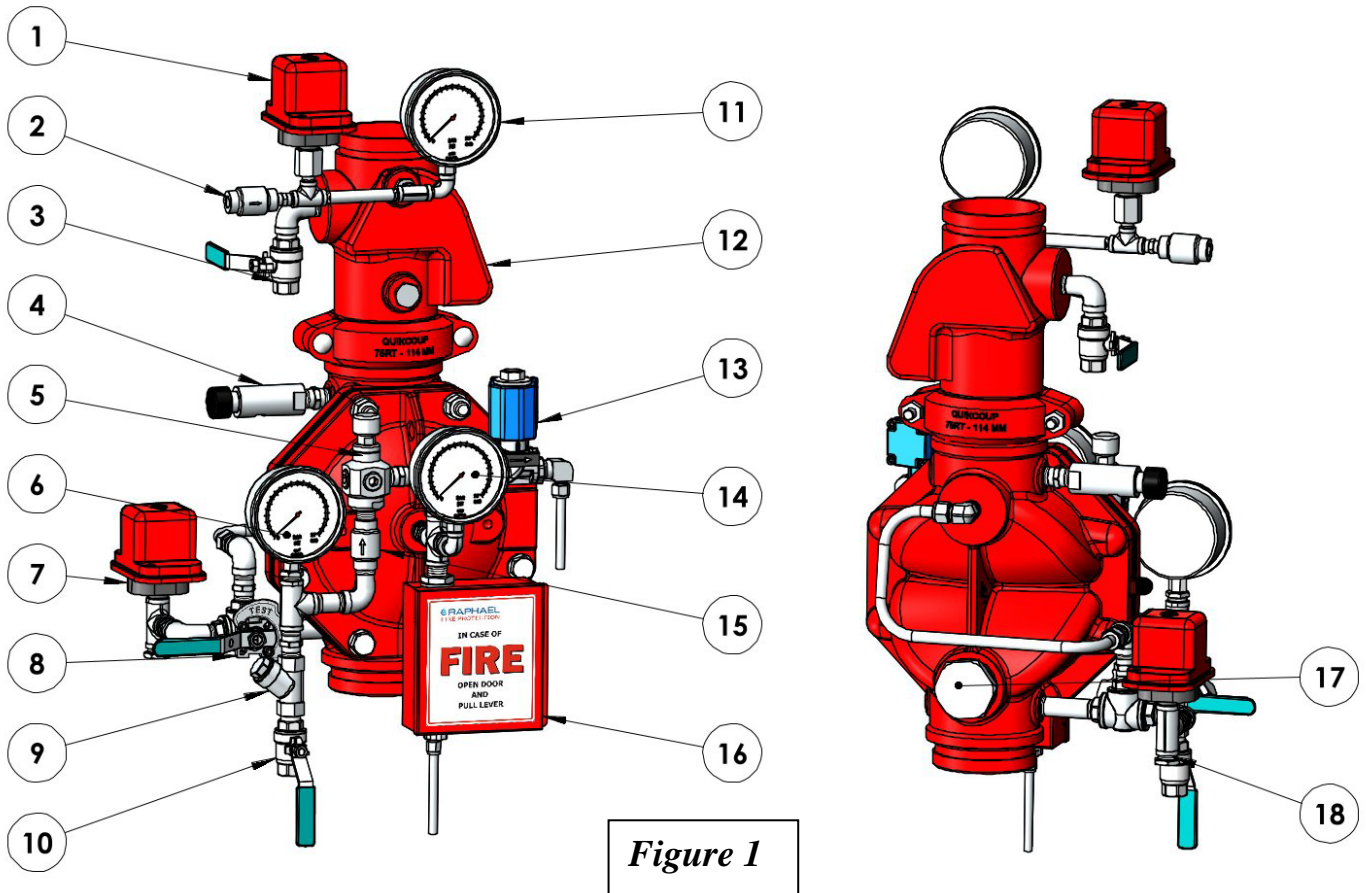

Figure 1

Installation (reference - figure 2)

1. This system is supplied pre-assembled and factory pre-adjusted. Any change carried out at the system's trim components adjustments or order, pipe and tubes length or ports for axillary connection sizes, will affect the system operation and therefore, prohibited.
2. The system (the FDV valve and the riser check valve), cannot be installed at a location where it might be subjected to freezing temperatures.
3. Sufficient room around the system location should be kept, to enable assembly/disassembly and maintenance work.
4. It should be considered that water will be drained during regular maintenance on a routine basis, during periodical tests procedures and when operating in fire situations. Therefore, a drainage plan should be considered.
5. The system described is to be mounted vertically only. Systems with identical operation but for horizontal installation are marked with a prefix "H", e.g. HFPS-DIE0.
6. It is essential that the PSA's installation orientation will be vertical only, regardless of the deluge valve orientation.
7. The downstream pipe connected to the riser check valve needs to be supported firmly to prevent the pipeline's weight from being loaded on the system.
8. Any use of pipe/thread reduction-fittings installed at open ports designated for axillary components, (like water motor alarm, pressure switch, trim pressure supply, FPS valve's drains, solenoid drainpipe, etc.), is prohibited.
9. All connections to water supply, alarms etc. should be done in accordance with figure 2:
 - (1) – Trim pressure supply connection (1/2" NPT female)
 - (6) – Water motor alarm connection (connect 1/2" to 3/4" NPT nipple) - optional
 - (7) – Pressure switch connection – optional (1/2" NPT female)
 - (4&5) – ASK In and Out air connections (1/4" NPT female)
 - (11) – riser check valve drain ball valve (1/2" NPT female)
 - (12) – air supply check valve (1/4" NPT female)
 - (20) – MEU emergence valve drain tube (3/8" tube).

10. Pressure switch wiring:

Alarm pressure switch (7) need to be wired using the N.O. contacts so its function will be: closing contacts at pressure **increase**.

Air pressure alarm switch (14) need to be wired using the N.C. contacts so its function will be: closing contacts at pressure **decrease**.

Installation parts list

(reference - figure 2)

1. Trip supply valve (1/2" NPT female)
2. "Y" Strainer
3. 3-way Test/Set ball valve
4. ASK air supply unit fast filling valve (1/4" NPT female)
5. ASK air supply unit fast supply valve (1/4" NPT female)
6. Water motor alarm connection * (1/2" NPT female)
7. Alarm pressure switch * (1/2" NPT female connection)
8. Upstream presser gauge
9. MADV manual automatic drain valve
10. PSA Pressure Supply Arrestor
11. Air / water drain valve on riser check valve Main control board
12. Air supply check valve
13. Main control board
14. Air pressure switch (in the scope of supply)
15. Heat/Smoky detection sensors
16. Downstream separation butterfly valve.
17. Air pressure gauge
18. Solenoid valve (2 way)
19. Control chamber pressure gauge
20. MEU manual Emergency Unit
21. Upstream separation butterfly valve.

* **Optional**

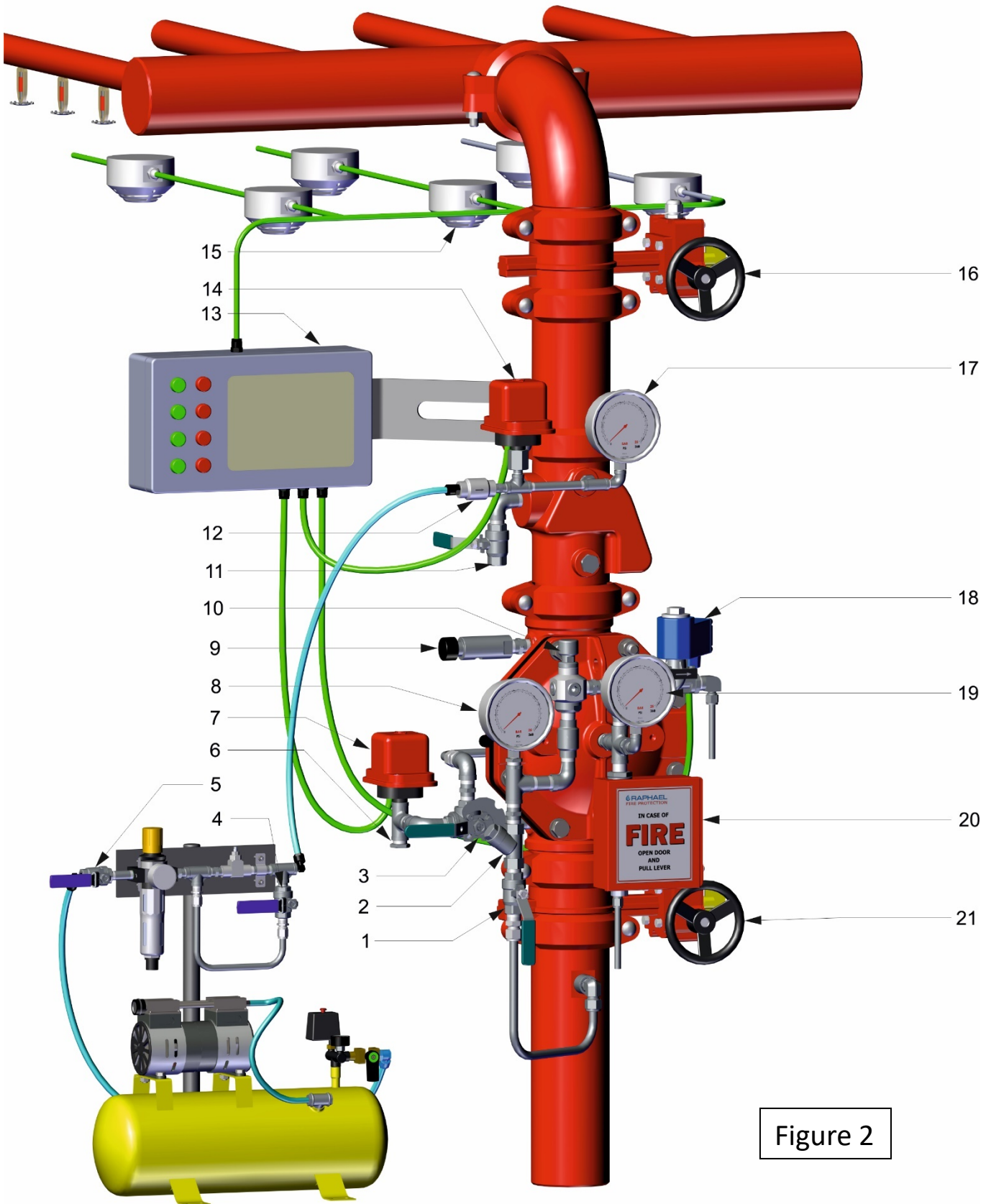

Figure 2

Operation instructions

Commissioning the system - phase 1.

Filling and pressurizing the system.

The procedure described should be carried out after system installation completion and a comprehensive inspection.

(Reference drawing - figure 2)

1. Close the Upstream & Downstream butterfly valves (**16 & 21**).
2. Make sure the solenoid (**18**) is de-energized.
3. Close the trim pressure supply ball valve (**1**).
4. Make sure that the Emergency valve at the MEU (**21**) is fully closed.
5. Open the Air supply flow rate selection ball valve, mounted vertically at the ASK (**4**), move its handle to the horizontal position and open the supply ball valve of the ASK (**5**).
6. Pressurize the sprinkler's pipeline to set pressure – observe air pressure gauge (**17**). When the pipeline has been fully pressurized, move the Air supply flow rate selection ball valve handle to the vertical position (**4**).
7. It is recommended to verify the system's sealing by closing the ASK air supply valve (**5**) and monitoring air pressure for over 1 hour. If no air pressure decrease was observed, re-open the ASK air supply valve (**5**).
Note: the ASK needle valve opening is factory set and should not be changed.
8. If ok, open the trim supply ball valve (**1**) and press the PSA (**10**) push-button until both pressure gauges **8 & 19** show the same reading. By that, the Deluge control chamber becomes pressurized, and the valve is closed.
9. Open the upstream butterfly valve (**21**).
10. Push the MADV (**9**) push-button and drain the space between the riser check valve and the deluge valve downstream – the “intermediate chamber”. Note that air leakage indicates a clapper sealing malfunction and water leakage indicates FDV sealing issue.
11. If ok, open the downstream butterfly valve (**16**).

The system is ready for the fire situation simulation.

Commissioning the system - phase 2.

Fire Situation Simulation

The procedure described, should be carried out after the system was pressurized and a comprehensive leakage inspection was commissioned.

Energizing the solenoid can simulate a fire situation and cause the system to response by opening the FDV deluge valve.

NOTICE:

Prior to any stoppage of the fire protection system, a fire patrol should be placed in the area covered by the interrupted system.

Prior to generating any test procedures, turning on false alarms or turning off the alarm system, the local safety personnel and the close central fire station must be reported.

(Reference drawing - figure 2)

1. Make sure that downstream butterfly valve (16) is close
2. De-pressurize the space between the check valve's clapper and the downstream butterfly valve by opening Clapper Check valve drain-valve (11).
3. Make sure that the Air pressure switch transfers a signal to the main control board (13).
4. Initiate false alarm activation, for fume or heat detection sensors system at the control board (13), to energize and open the SOV, and drain the FDV control chamber. The FDV deluge valve should open, forces the check valve's clapper to open as well and admit water into the blocked spray sprinklers pipeline part.
5. Water should run out of the open Clapper-Check-valve drain-valve (11). Both alarms (water motor alarm & pressure switch, should be activated.
6. Stop the false alarms at the main control board to de-activate the SOV (18). make sure that the Preaction system continue admitting water through the riser check valve's drain valve. By that, the PSA's operation as a latching device was verified.

End of Fire Situation Simulation

Commissioning the system - phase 3.

Resetting & placing in service

The procedure described, should be carried out after any periodic operational test, simulated or real fire situation.

After a real fire situation, make sure that the SOV is closed by de-energizing its coil (through the FP main control board). (Reference drawing - figure 2)

1. Close the upstream butterfly valve (21).
2. Close the air supply ball valve at the ASK (5).
3. Drain the downstream pipeline part through the riser drain valve (11) and open the air supply ball valve at the ASK. In addition, open the needle valve bypass ball valve and let the air stream “push” the leftover water out of the pipe part.
4. When the air stream looks dry and no water drops can be seen drifting through the open drain valve outside, close the drain valve (11) and pressurize it to set pressure. Observe the air pressure gauge (17) for the set reading.
5. Press the push button of the PSA to fill and pressurize the deluge valve control chamber. Push the button until the pressure gauges 8&19 becomes the same. This will close the deluge valve.
6. Gradually open the upstream butterfly valve (21).
7. Press the push button of the MADV drain valve and drain the space between the closed FDV deluge valve diaphragm, and the riser check valve clapper – the “Intermediate chamber”.
If a dripping or leakage is observed, there is a sealing issue at the FDV deluge valve. If you hear or feel an air leak noise, there is a sealing issue at the riser check valve clapper.
8. Open downstream butterfly valve (16) the ASK will compensate any air pressure loss to set pressure.
9. Move the needle valve bypass ball valve at the ASK back to its close state.
10. Close the supply ball valve at the ASK and check for any air pressure decrease at list for 1 hour. If ok, fully open this ball valve.

The system is in SET state and placed in service.

Maintenance

Prior to any stoppage of the fire protection system, a fire patrol should be placed in the area covered by the interrupted system.

Prior to generating any test procedures, turning on false alarms or turning off the alarm system, the local safety personal and the close central fire station must be notified.

Maintenance and inspection procedures follow the NFPA 25 instructions for deluge valves.

Daily Inspection

Make sure that the deluge valve's heating system (If equipped), functions correctly and that the Fire protection valve surrounding temperature is 4°C min.

Monthly Inspection

1. Observe the preaction system for external damage: observe the piping and hose connections for leakage or damage.
2. Verify that the upstream butterfly valve (21) and the Trim pressure supply valve (1) are in fully open position. Upstream drain valve (if equipped) is fully close.
3. Press the PSA push-button (10) for about 5-10 sec. to assure that FDV valve control chamber is pressurized and then, release.
4. Push the MADV (9) and make sure that after emptying condensing water, the drain flow/dripping stops. If a constant leakage is observed, it might indicate a deluge valve sealing problem.
5. Move the 3-way SET/TEST valve to TEST (3). The acoustic alarm should sound, and alarm pressure switch (7) should transmit a signal to the main control board.

Annual test procedure

1. Conduct the monthly inspection procedure.
2. Perform the procedure described in chapter - **Commissioning the system - phase 2.** - Fire Situation Simulation. Check and confirm the system's proper operation.
3. Follow the procedure described in chapter - **Commissioning the system - phase 3.** - Resetting & placing in service. Check and confirm the system's proper operation.

Periodic testing of systems for pressure leakage

once every 3 years for air leakage, using one of the following test methods:

With the system at normal system pressure, shut off the air source (compressor or shop air) for 4 hours. If the low air pressure alarm goes off within this period, the air leaks shall be addressed.

Every 5 years inspection procedure

This major inspection and maintenance procedure includes the removal of the trim, the dismantling of the FDV's valve cover and a performance of a comprehensive internal part examination. Then, the relevant trim accessories should be maintained, referring their maintenance instruction. After the completion, the Annual maintenance procedure is to be conducted.

1. Close the upstream butterfly valve (**21**) and the trim pressure supply valve (**1**).
2. Open the upstream drain valve (if equipped). Drain the FDV's control chamber using the EMU Emergency valve (**20**).
3. Turn off or disconnect all relevant electrical circuits.
4. Release all relevant tubes fitting nuts and the central union pipe connection (if equipped) at valves cover center.
5. Remove the disassembled trim.
6. Remove all the FDV's cover bolts. The cover will hang on its studs (4" and up). Release both nuts and remove the cover carefully.
7. Observe the internals of the valve and cover for excessive scale residuals, foreign particles, damaged coating (rust, cracks, or peeling).
8. Worn or damaged parts should be replaced. Consult Raphael's local representative or the service department for any maintenance issue or part replacement issue.
9. Replace the Diaphragm. The identification tongue should point to the valve's stamped size (diameter in inch) side.
10. Reinstall the valve's cover: use the Anti-seize paste tube supplied in the maintenance kit for bolts and nuts lubrication. Tight them in accordance with "Bolt's torque moments table".
11. Reinstall the trim carefully: avoid causing twists or dents on bent tubes and do not overtight the compression fitting's nuts.

12. When the system is fully reassembled, perform the “**Commissioning the system - phase 1** - Filling and pressurizing the system” procedure.
13. Perform the “**Annual maintenance procedure**”.

Bolt’s Torque Moments Table

Valve size	1.5”	2”	2.5”	3”	4”	6”	8”	10”
Torque lb/ft	22	29	36	54	65	72	87	118

Equivalent pipe length for FDV deluge valves

Valve size	Equivalent length value ft (m)
1.5”	11 (3.6)
2”	24 (7.3)
2.5”	25 (7.6)
3”	28 (8.5)
4”	31 (9.4)
6”	46 (14)
8”	72 (21.9)
10”	117 (35.6)

Marking

The FDV valves are marked by a laser engraved, black anodized, 0.8mm (0.031”) thick metal plate, riveted to the valve’s cover.

The marking plate contains the data about (top to bottom):

- *Company name and trademark.*
- *Short description (Italic letters)*
- *Application’s type:* FPS-DIE0 – Double Interlock, Electric /Electric actuation with Local Reset Preaction system
- *(P/N) The Application’s part number:* System properties–Valve properties
- *Rated pressure:* 250 psi
- *Equivalent Length:* reference table - page 14.
- *Serial Number:* Work order number-MM-YY-Number in batch 01-99
- *The UL listing mark & QR code:* EXxxxxx
- *The FM approved mark*
- *The Application’s diameter in inch: XX”*

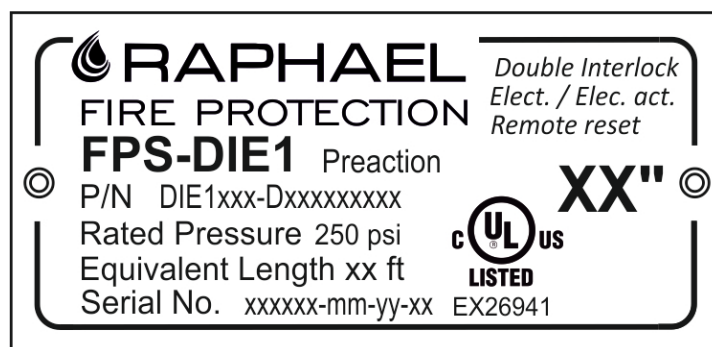

Double Interlock Preaction - Electric-Electric Actuation, Local Reset, Type: FPS-DIE0

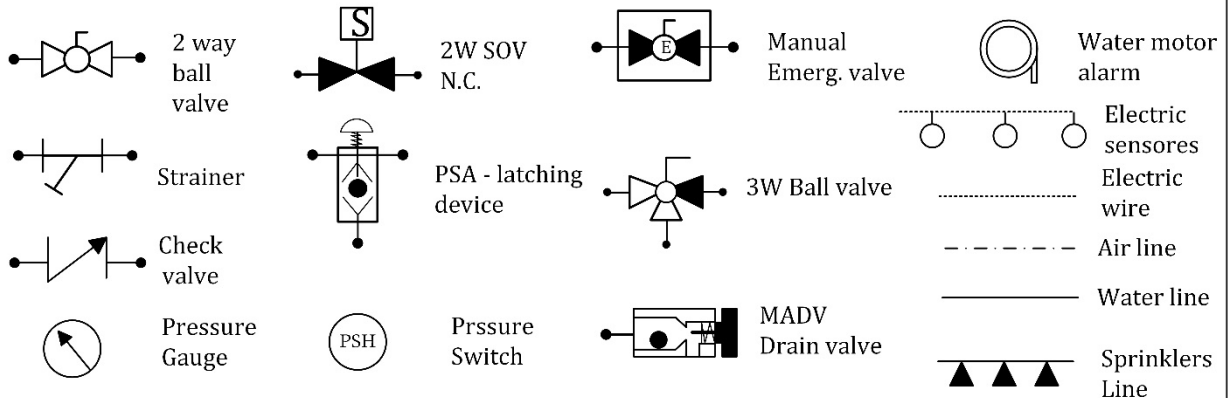
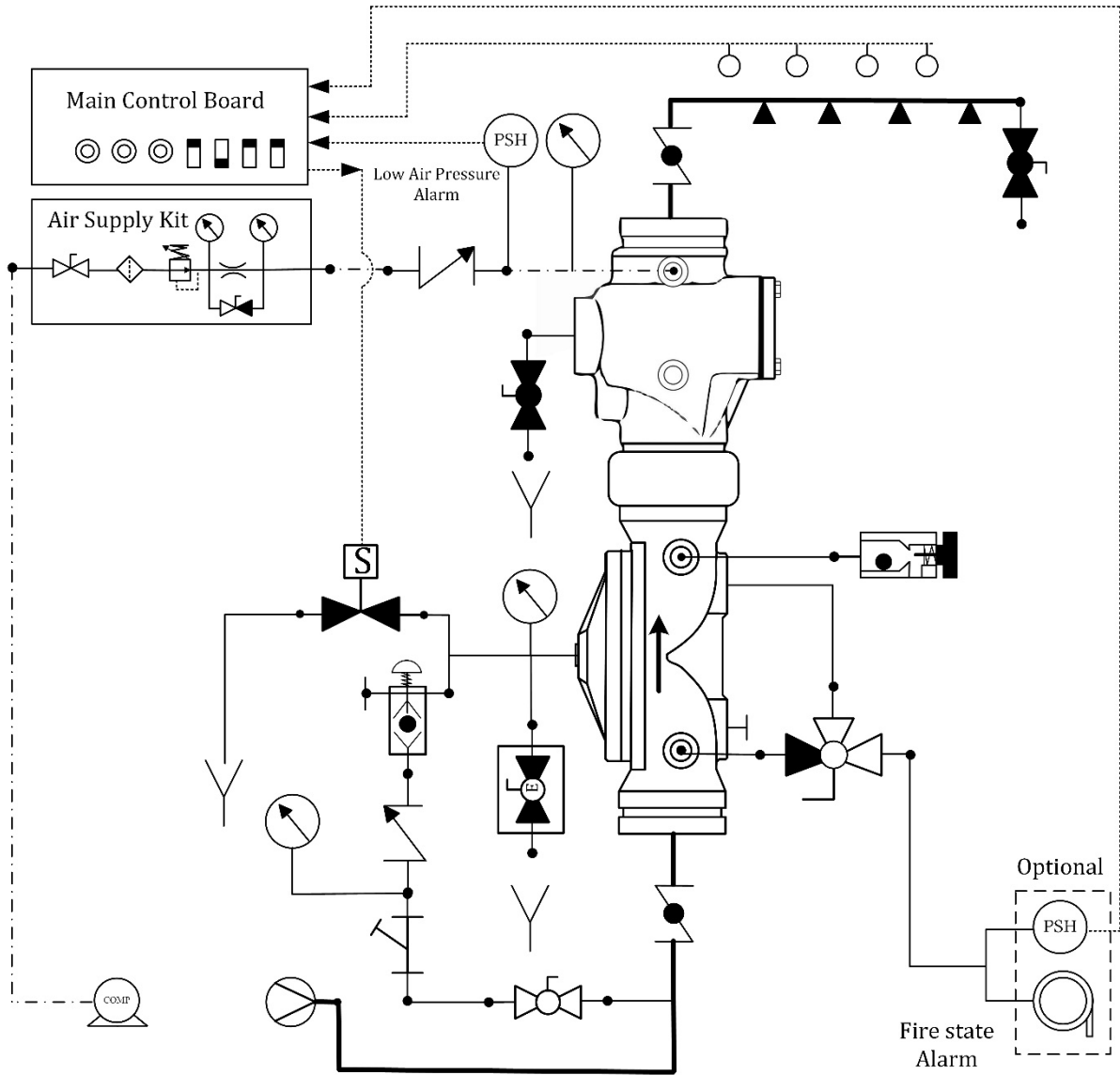

RAPHAEL, founded in 1949, is the first Israeli manufacturer of water control valves. **RAPHAEL**'s research department constantly strives to introduce new and innovative products and solutions for water control systems including water works, fire-protection and irrigation systems.



Waterworks



Fire Protection



Irrigation



Smart Solutions

 **RAPHAEL**

RAPHAEL Valves Industries (1975) Ltd.

North Industrial Zone Or Akiva, 3063927 P.O.Box 555, Israel

Tel. +972 4 6263555 | info@raphael-valves.com | raphael-valves.com