

IOM FDV-3W-DE1

3 WAY ELECTRIC ACTUATED WITH REMOTE RESET DELUGE VALVE

Installation **O**peration & **M**aintenance manual

Fire Protection

RAPHAEL VALVES INDUSTRIES

3 Way Electric Actuated with Remote Reset Deluge Valve

Description

This deluge system is based on Raphael's FDV valve, equipped with three-way hydraulic actuated control trim. The valve and its trim have a range of optional materials and coating to fulfill various operation and ambient conditions, but the system function principle stays unchanged: in fire situation, an electric detection system, (smoke or heat detection), trips the 3-way solenoid valve that actuates the 3-way actuator. Consequently, the actuator drains the pressurized control chamber, and the valve opens. The 3-way operation assures the full opening of the deluge valve, delivering the maximum flow to the sprinklers pipeline.

The fully accessorized valve can be supplied under a flexible scope in terms of specials accessories properties (for seawater, brackish water, explosion proof etc.)

The system is suitable for water spray pipelines with open nozzles.



Parts list

1. – Upstream pressure gauge
2. – Check Valve (plugged, 1/2" NPT female)
3. – "Y" Strainer
4. – Alarm pressure switch (1/2" NPT Female).
5. – Trim Pressure Supply Valve
6. – Alarm test 3-way valve
7. – MEU Manual Emergency Unit
8. – 3 way solenoid
9. – Orifice
10. – Control chamber pressure gauge
11. – 3-way hydraulic actuator valve
12. – Downstream drain valve (1/2" NPT female)
13. – WMA water Motor Alarm connection (1/2" NPT female).
14. – Upstream drain port (plugged)

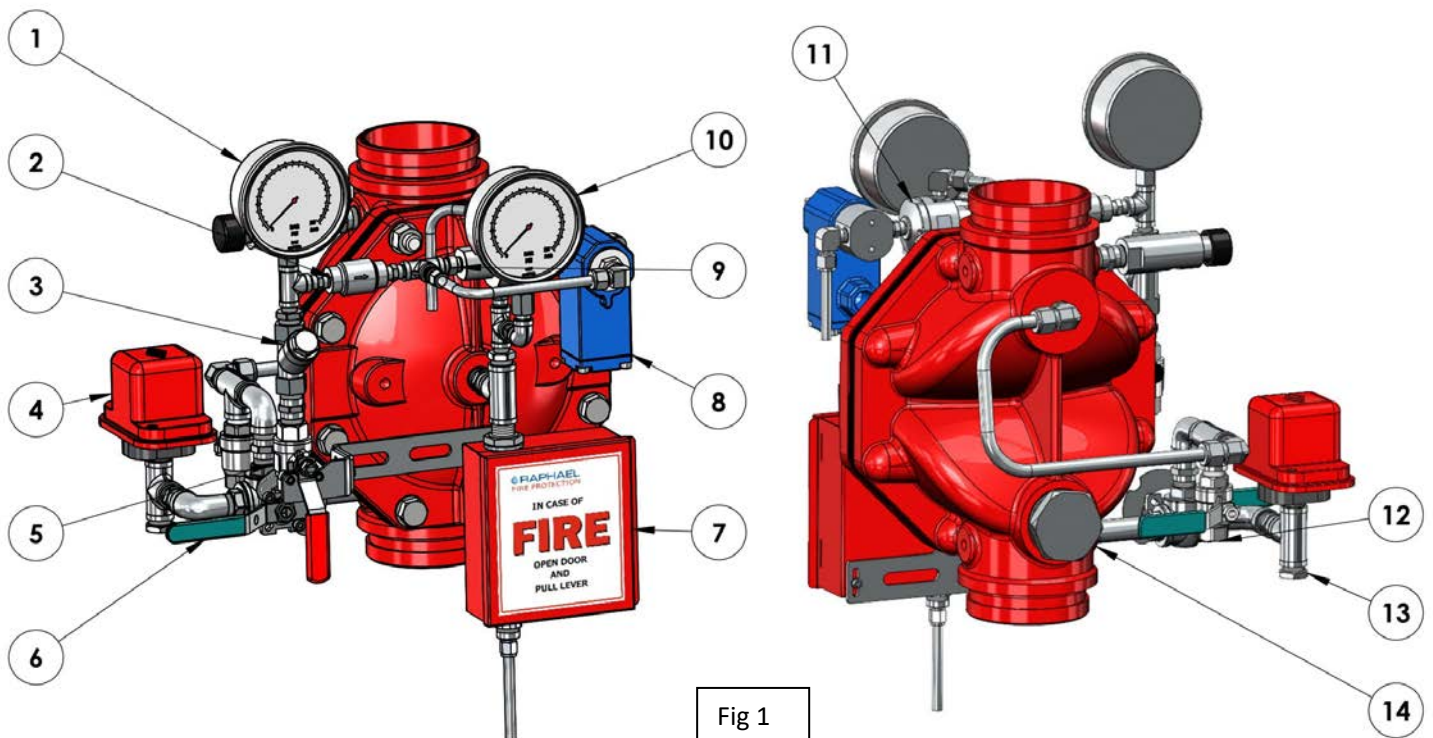

Operation (Reference Figure 1)

SET position:

Water is supplied by the trim supply valve (5), through the “Y” strainer (3), check valve (2) through the HAV-3 actuator (11), and fills the FDV’s control chamber. Pressurized water in the FDV valve’s control chamber is trapped by the check-valve (3), and by the closed Emergency valve unit (7), maintaining the deluge valve in closed position.

The free pass of upstream pressure through the closed SOV (8), keeps the HAV-3 actuator’s control chamber pressurized and consequently, the actuator enables upstream to pressurize the control chamber of the deluge valve. Therefore, the deluge is drip-tight close.

Fire Situation

When one or more of the heat or smoke detectors is triggered, the main FP control board transmits an electric pulse (in case of latching SOV) or continues signal (regular SOV) to the solenoid’s coil (8).

When energized, the open SOV drains the HAV-3 control chamber and shifts it to its OPEN state. Consequently, the FDV deluge valve’s control chamber pressure is drained through the actuator’s vented path and the opened deluge valve admits water into the sprinklers pipeline/s.

Opening the Emergency valve (7) bypasses all conditions, drains the FDV valve’s control chamber and opens the valve immediately.

Reset Position

Resetting this system requires stopping the alarm at the main control FP board and interrupting the electrical signal to the SOV coil (or transmitting another pulse to a SOV’s latching coil). The closed SOV pressurizes the HAV-3 actuator’s control chamber and moves to its the CLOSE state. Consequently, the FDV deluge valve’s control chamber is pressurized and the deluge valve closes. The nozzles spray stops, and the system moved into the SET position.

Installation (Reference Figure 2)

1. This system is supplied pre-assembled and factory pre-adjusted. Any change carried out at the system's trim components adjustments or order, pipe and tubes length or ports for axillary connection sizes, will affect the system operation and therefore, prohibited.
2. The system cannot be installed at a location where it might be subjected to freezing temperatures.
3. Sufficient room around the system location should kept enabling assembly/disassembly and maintenance work.
4. It should be taken by account that water will be drained during regular maintenance on a routine base, during periodical tests procedures and when operating in fire situation. Therefore, a drainage plan should be considered.
5. The system described, is to be mounted vertically only. Systems with identical operation but for horizontal installation are marked with a prefix "H", e.g. HFDV-AE1.
6. The downstream pipe connected to the FDV valve at a horizontal or vertical mount, must be supported firmly to prevent the pipeline's weight to be loaded on the system's valve.
7. Any use of pipe/thread reduction-fittings installed at open ports designated for axillary components, (like water motor alarm, alarm pressure switch, trim pressure supply, FDV valve's drains, etc.), is prohibited.
8. All connections to water supply, alarms etc. And other optional equipment should be done in accordance with **fig 1**:
 - * **(4)** – Pressure switch connection port (all 1/2" NPT female)
 - * **(3)** – Water motor alarm connection
 - * **(1)** – Trin supply ball valve (1/2" NPT female)
 - * **(5)** – Downstream drain ball valve (1/2" NPT female)
9. The FDV valve should be installed with the flow arrow marked on the valve's body, in the proper direction.

Installation parts list

(reference - figure 2)

1. Trim supply valve (1/2" NPT female)
2. 3-way alarms test ball valve
3. WMA Water Motor Alarm
4. Alarm pressure switch (1/2" NPT female)
5. Downstream drain valve (1/2" NPT female)
6. "Y" Strainer
7. MADV Manual Automatic drain valve.
8. Upstream pressure gauge
9. Check valve
10. Main Control hub
11. Electrical heat sensor
12. Downstream separation valve (butterfly or OS&Y valves).
13. Control chamber pressure gauge
14. 3-way Solenoid valve
15. Manual Emergency valve
16. Upstream separation valve (butterfly or OS&Y valves).

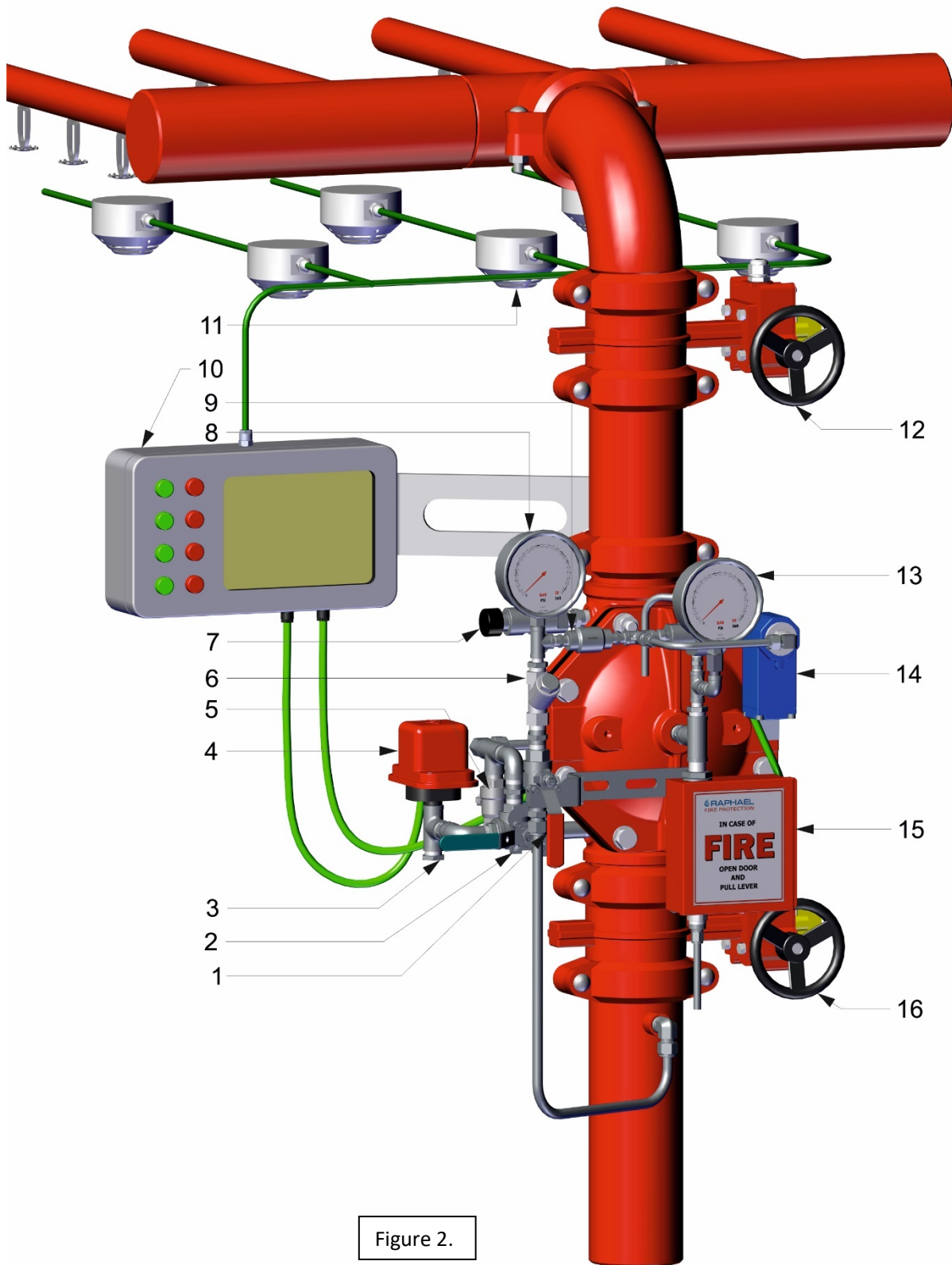

Figure 2.

Operation instructions (Reference Drawing - figure 2)

Commissioning the system - Phase 1

Filling and pressurizing the system.

The procedure described should be carried out after system installation completion and a comprehensive inspection.

1. Make sure the upstream butterfly valve (**16**) is fully close.
2. Make sure the trim pressure supply ball valve (**1**) is Closed.
3. Make sure that the MEU - Emergency valve unit (**15**) is fully closed.
4. Make sure SOV (**14**) coil is de-energized.
5. Open the downstream drain valve (**5**)
6. Open the trim pressure supply valve (**1**).
7. Gradually open the upstream butterfly valve (**16**) and make sure the downstream drain valve is not dripping. A dripping might indicate a FDV valve sealing issue.
8. leave the Downstream drain valve (**5**) open.

The system is ready for the Fire situation simulation.

Commissioning the system - Phase 2

Fire Situation Simulation (Reference Drawing - figure 2)

The procedure described, should be carried out after the system was pressurized and a comprehensive leakage inspection was commissioned.

Energizing the solenoid can simulate a fire situation and cause the system to response by opening the FDV deluge valve.

NOTICE:

Prior to any stoppage of the fire protection system, a fire patrol should be placed in the area covered by the interrupted system.

Prior to generating any test procedures, turning on false alarms or turning off the alarm system, the local safety personnel and the close central fire station must be reported.

(Reference drawing - figure 2)

1. Close the downstream butterfly valve (**12**) and make sure that the FDV's downstream drain valve (**5**) is open.
2. Initiate a false alarm at the main FP control board (**10**) and energize the SOV coil.
3. Observe the FDV's control chamber drain through the drain tube located behind the control chamber pressure gauge (3/8" tube open to the atmosphere). The flow should stop after a few tens of seconds.
4. Observe the water flow through the open FDV's downstream drain valve (**5**). A significant flow should flow out the open valve.

System is ready for re-setting and placing in service.

Commissioning the system - phase 3.

Resetting & placing in service (Reference Drawing - figure 2)

The procedure described, should be carried out after any periodic operational test - simulated or real fire situation. After a real fire situation, replace all blown-open sprinklers before pressurizing the pilot line.

1. Turn off the false alarm at the main FP control board. The SOV coil should become de-energized (or receive another electric pulse, in case of latching solenoid). The FDV valve should close.
2. Close the upstream butterfly valve **(16)**
3. Close the trim pressure supply valve **(1)**.
4. Clean the trim strainer's screen **(6)**. Re-assemble the strainer's screen.
5. Open the trim pressure supply valve.
6. Open the upstream separation butterfly valve **(16)**. The FDV valve should remain closed.
7. Observe the downstream drain valve **(5)** or push the MADV **(7)** push-button and drain the spray pipeline. At drainage end, close this valve.
8. Open the downstream separation butterfly valve **(12)** and close the deluge drain valve **(5)**.

System is in SET state and placed in service.

Maintenance

Prior to any stoppage of the fire protection system, a fire patrol should be placed in the area covered by the interrupted system.

Prior to generating any test procedures, turning on false alarms or turning off the alarm system, the local safety personal and the close central fire station must be notified.

The Maintenance and inspection procedures are based on the relevant chapters at the NFPA 25.

Daily Inspection

Make sure that the deluge valve's heating system (If equipped), functions correctly and that the Fire protection valve surrounding temperature is 4°C min.

Monthly Inspection

1. Observe the FDV deluge valve and its trim for external damage: observe the trim piping and hose connections for leakage or damage.
2. Verify that the upstream and downstream separation butterfly valves (**12 & 16**) and the Trim pressure supply valve (**1**) are in fully open position.
3. Open the downstream drain valve or push the MADV push-button. Make sure there is no leakage or dripping. When done, close this ball valve.
4. Move the 3-way ball valve handle for set to test. The alarm pressure switch should send a signal to the main control hub, and the acoustic alarm (WMA) should sound.

Annual test procedure

1. Conduct the monthly test & inspection procedure.
2. Perform the procedure described in chapter - **Commissioning the system - phase 2**. - Fire Situation Simulation. Check the system's proper operation.
3. Follow the procedure described in chapter - **Commissioning the system - phase 3**. - Resetting & placing in service, chapter **Resetting & placing in service**.

Every 5 years inspection procedure

This major inspection and maintenance procedure includes the removal of the trim, the dismantling of the FDV's valve cover and a performance of a comprehensive internal part examination. Then, the relevant trim accessories should be replaced, After the completion, the Annual maintenance procedure is to be conducted.

1. Close the upstream butterfly valve (16) and the trim pressure supply valve (1).
2. Open both upstream and downstream drain balls if equipped and drain the deluge valve. Drain the FDV's control chamber using the Emergency valve (15).
3. Turn off or disconnect all relevant electrical components and wiring.
4. Release all relevant tubes, fitting nuts at valves cover centre. Remove the support bracket connecting the back of the MEU box with the trim pressure supply valve.
5. Remove and disassembled front trim.
6. Remove all the FDV's cover bolts. The cover will hang on its studs (4" DN100 valve size and up). Release both nuts and remove the cover carefully.
7. Observer the internals of the valve and cover for excessive scale residuals, foreign particles, damaged coating (rust, cracks, or peeling).
8. Worn or damaged parts should be replaced. Consult Raphael's local representative or the service department for any maintenance issue or part replacement issue.
9. Replace the Diaphragm. The identification tongue should point to the valve's stamped size side (from top view – at the left side).
10. Reinstall the valve's cover: use the Anti-seize paste supplied in the maintenance kit for bolts and nuts pre-installation lubrication. Tight it in accordance with "**Bolt's torque moments table**".
11. Reinstall the front trim carefully: avoid causing twists or dents on bent tubes and do not overtight the compression fitting's nuts.
12. When the system is fully re-assembled, perform the "**Commissioning the system - phase 1** - Filling and pressurizing the system" procedure.
13. Perform the **Annual test procedure**.

Bolt's Torque Moments Table

Valve size	1.5"	2"	2.5"	3"	4"	6"	8"	10"
Torque lb/ft	22	29	36	54	65	72	87	118

Equivalent pipe length for FDV deluge valves

Valve size	Equivalent length value ft (m)
1.5"	11 (3.6)
2"	24 (7.3)
2.5"	25 (7.6)
3"	28 (8.5)
4"	31 (9.4)
6"	46 (14)
8"	72 (21.9)
10"	117 (35.6)

Marking

The FDV valves are marked by a laser engraved, black anodized, 0.8mm (0.031”) thick metal plate, riveted to the valve’s cover.

- *Company name and trademark.*
- *Short description (Italic letters)*
- *Application’s type:* FDV-3W-DE1, 3-way Electric actuated, Remote Reset.
- *(P/N) The Application’s part number.* System properties–Valve properties
- *Rated pressure:* 250 psi
- *Equivalent Length:* reference table - page 12.
- *Serial Number.* Work order number-MM-YY-Number in batch 01-99
- *The UL listing mark & QR code:* EXxxxxx
- *The Application’s diameter in inch:* XX”

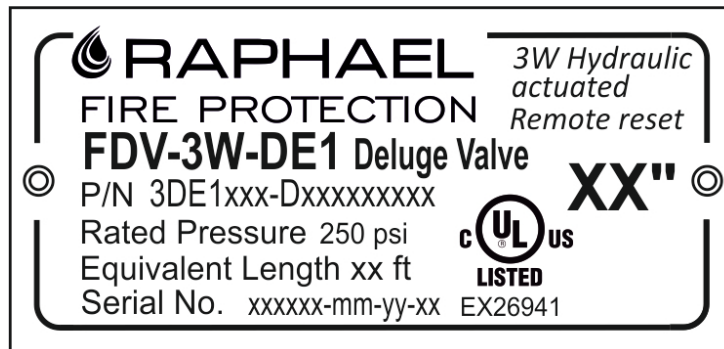

Electric actuated, 3 Way Operation, Remote Reset FDV Deluge valve, Type: **FDV-3W-DE1**

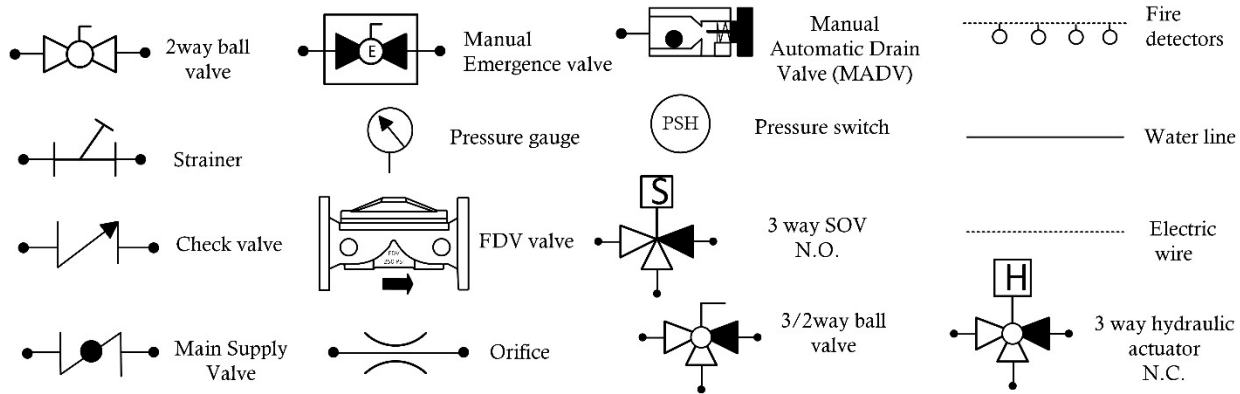
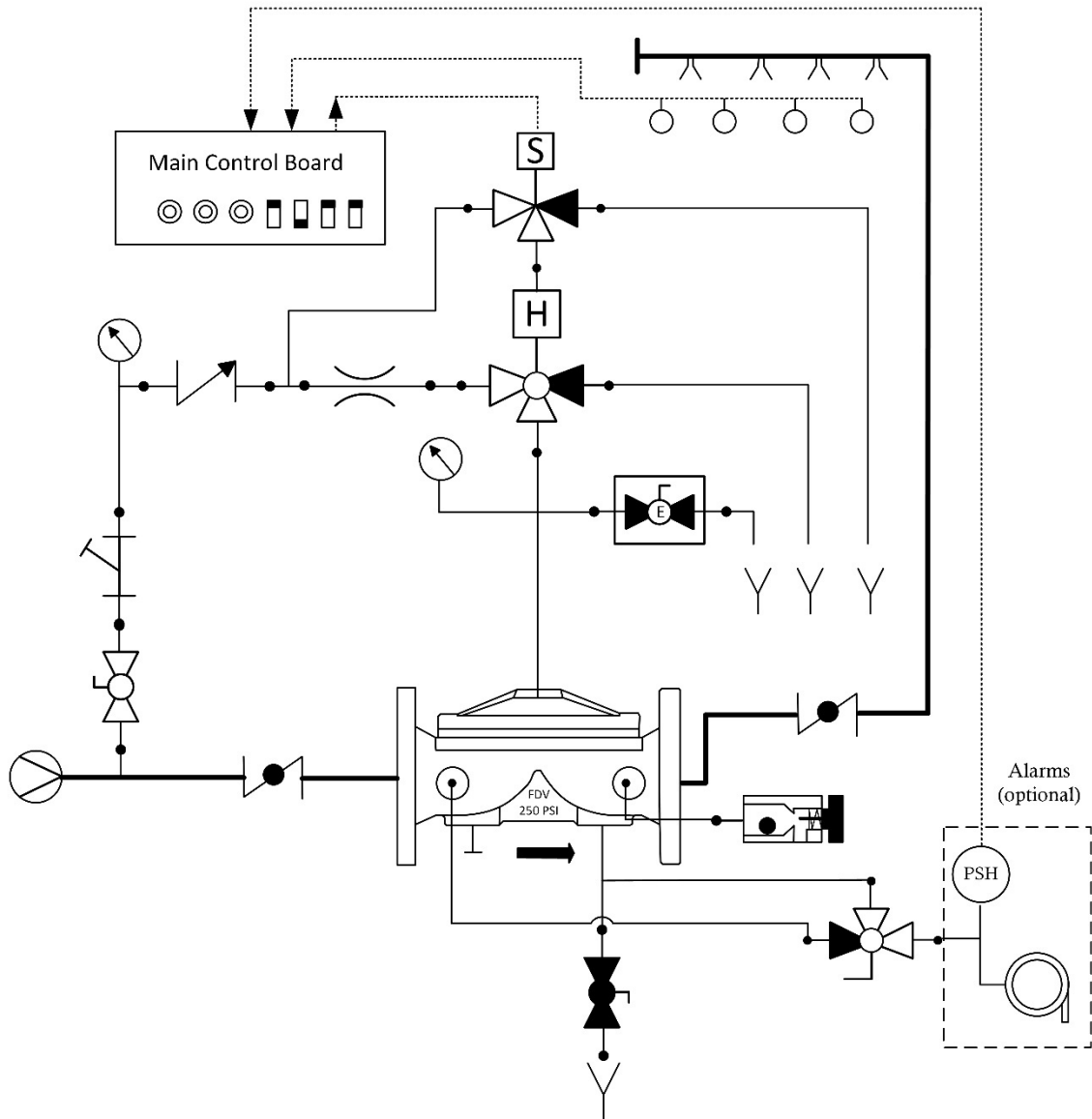

RAPHAEL, founded in 1949, is the first Israeli manufacturer of water control valves. RAPHAEL 's research department constantly strives to introduce new and innovative products and solutions for water control systems including water works, fire-protection and irrigation systems.



Waterworks



Fire Protection



Irrigation



Smart Solutions

 **RAPHAEL**

RAPHAEL Valves Industries (1975) Ltd.

North Industrial Zone Or Akiva, 3063927 P.O.Box 555, Israel

Tel. +972 4 6263555 | info@raphael-valves.com | raphael-valves.com